

# City of Las Cruces Design Standards

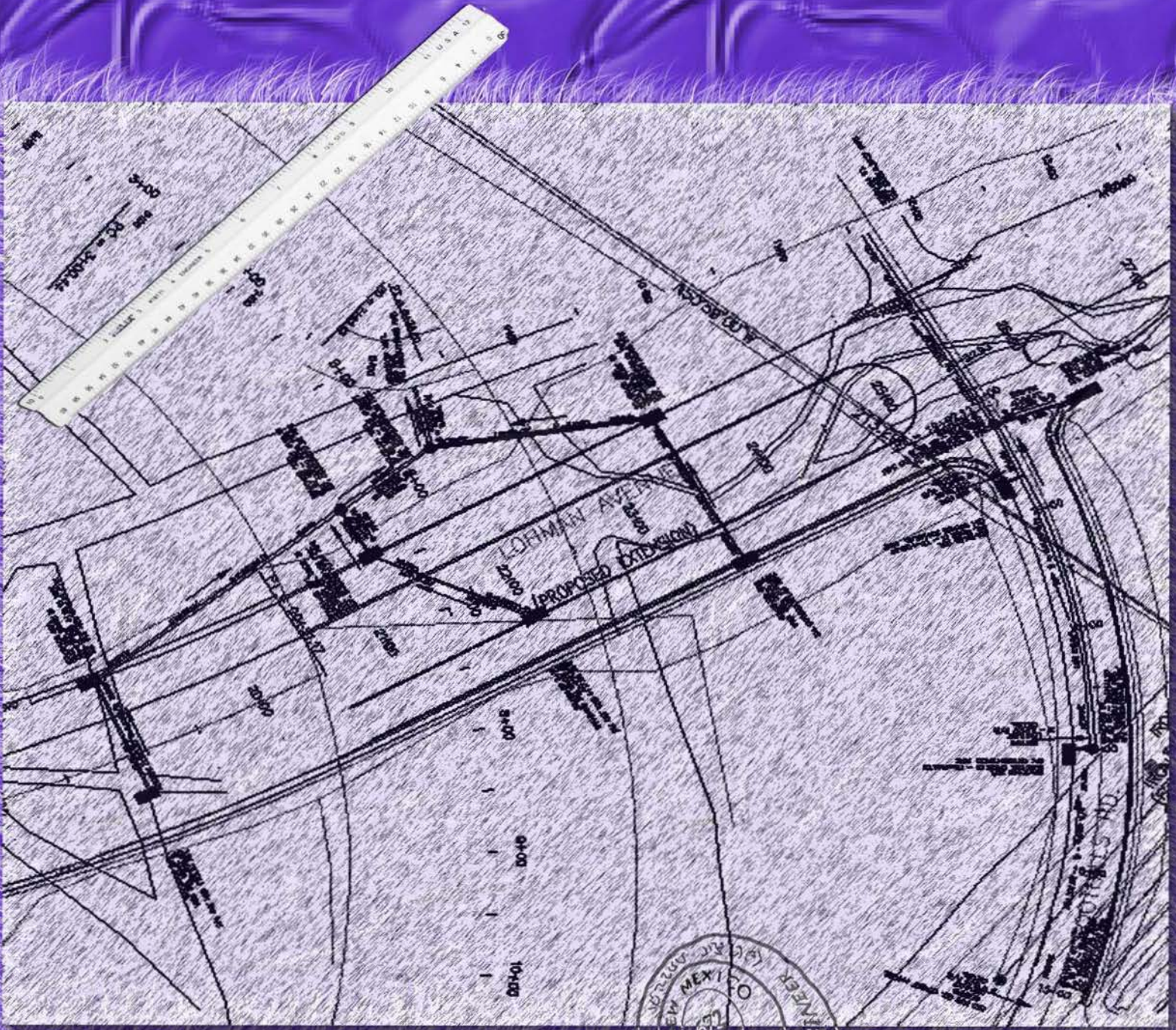

V. 4-4-2005



## Chapter 32

### DESIGN STANDARDS\*

---

\* **Cross References:** Streets and sidewalks, ch. 26; utilities, ch. 28; buildings and building regulations, ch. 30; development impact fee, ch. 33; drainage and flood control, ch. 34; excavations and curb cuts, ch. 35; subdivisions, ch. 37; design standards for subdivisions, § 37-266 et seq.; zoning, ch. 38.

---

#### Article I. In General

Sec. 32-1. Title.  
Sec. 32-2. Definitions.  
Sec. 32-3. Purpose.  
Sec. 32-4. Statutory authority and jurisdiction.  
Sec. 32-5. Interpretation and conflict.  
Sec. 32-6. Violations; penalties.  
Secs. 32-7--32-35. Reserved.

#### Article II. Standards for Public Rights-of-Way

Sec. 32-36. City Streets.  
Sec. 32-37. Sidewalk requirements.  
Sec. 32-38. Street lights--Specifications for installation.  
Sec. 32-39. Utility improvements.  
Sec. 32-39.1. Bicycle facilities.  
Sec. 32-40. Details.  
Secs. 32-41--32-70. Reserved.

#### Article III. Drainage

##### Division 1. Generally

Secs. 32-71--32-100. Reserved.

##### Division 2. Urban Drainage Criteria

Sec. 32-101. Introduction.  
Sec. 32-102. Storm definitions.  
Sec. 32-103. Runoff analysis methods.  
Sec. 32-104. Specific analysis requirements.  
Sec. 32-105. Hydraulics of storm drainage systems.  
Sec. 32-106. Detention pond design.  
Sec. 32-107. On lot ponding; minimum pad elevations.  
Sec. 32-108. Drainage system operation and maintenance.  
Secs. 32-109--32-135. Reserved.

##### Division 3. Fences and Walls and Retaining Walls

Sec. 32-136. Scope of division.  
Sec. 32-137. Definitions.  
Sec. 32-138--32-142. Reserved.  
Sec. 32-143. Wall design requirements.  
Sec. 32-144. Retaining wall design requirements.  
Secs. 32-145--32-175. Reserved.

##### Division 4. Soils Testing

Sec. 32-176. Specific standards.  
Secs. 32-177--32-235. Reserved.

**Division 5. Details**

**Sec. 32-236. Details.**  
**Secs. 32-237--32-265. Reserved.**

**Article IV. Development Standards for Landscaping**

**Sec. 32-266. Scope of article.**  
**Sec. 32-267. Definitions.**  
**Sec. 32-268. Locational criteria.**  
**Sec. 32-269. City-owned property or property dedicated to city.**  
**Sec. 32-270. Buffers and screens.**  
**Sec. 32-271. Site plan review.**  
**Sec. 32-272. Installation.**  
**Sec. 32-273. Maintenance.**  
**Sec. 32-274. Enforcement.**  
**Sec. 32-275. Variances.**  
**Sec. 32-276. Building permit required.**  
**Sec. 32-277. Plant materials.**  
**Sec. 32-278. Compliance.**  
**Sec. 32-279. Public sites and open spaces.**  
**Sec. 32-280. University Avenue corridor overlay zone district.**

**Article V. Standards for Erosion Control**

**Sec. 32-301. Soil and water erosion control.**  
**Sec. 32-302. Wind erosion control.**

**ARTICLE I.**

**IN GENERAL**

**Sec. 32-1. Title.**

This chapter shall be entitled "The City of Las Cruces and Five-Mile Planning and Platting Jurisdiction (Extraterritorial Zone) Design Standards" and may be referred to as "the design standards."  
(Ord. No. 949, § 1.1, 9-8-87)

**Sec. 32-2. Definitions.**

The following words, terms and phrases, when used in this chapter, shall have the meanings ascribed to them in this section, except where the context clearly indicates a different meaning:

*ADT* means average daily traffic, which is the total traffic for a year divided by 365.

*Alley* means a minor public way which is used primarily for vehicular service access to the back or side of properties otherwise abutting on a street.

*Ambient air* means that portion of the atmosphere, external to buildings, to which the general public has access. Land owned or controlled by the stationary source and to

which public access is precluded by a fence, physical barriers, or other effective means is exempted from the ambient air.

*Arterial street* means a street which is used primarily for serving large volumes of comparatively high-speed traffic from one area of the city to another.

*Asphalt treated base* means base course aggregate and bituminous material mixed in a central plant, spread and compacted on a prepared surface in substantial compliance with the specifications, lines, grades, thicknesses and typical cross section shown on the plans.

*Backfill* means that soil which is replaced in a hole after excavation and placement of irrigation lines, plant materials, conduits and structures.

*Bikepath* means a portion of a roadway or separate pathway designated for use by bicycles.

*Building setback* means the right angle distance from a point on or within street right-of-way to the closest point of any building structure.

*Channel* means any arroyo, stream, swale, ditch, diversion, or watercourse that conveys storm runoff, including manmade facilities.

*Channel stability* means a condition in which a channel neither degrades to the degree that structures, utilities or private property are endangered, nor aggrades to the degree that flow capacity is significantly diminished as a result of one or more storm runoff events or moves laterally to the degree that adjacent property is endangered.

*Channel treatment measure* means a physical alteration of a channel for any purpose.

*Chemical soil stabilization/suppression* means a method of dust control implemented by any person to mitigate PM10 emissions by applying petroleum resins, asphaltic emulsions, acrylics, adhesives, or any other approved material that are not prohibited for use by the city, the state environment department, the Environmental Protection Agency, or any other law, rule, or regulation.

*Collector street* means a street that carries traffic from local streets to the major arterial streets and highways.

*Construction and demolition activities* means any on-site activities preparatory to or related to building alteration, rehabilitation, removal or razing, or improvement on real property, including the placement and upkeep of mobile or manufactured homes or buildings. "Construction" also means construction of roadway systems including, arterials, expressways, interstates, tunnels, overpasses, bridges, interchanges, residential and commercial streets within a subdivision, and airport runway improvements.

*Control plan* means a written description of all reasonably available control measures (RACMs) to be implemented at a work site and/or in transit to and from a work site for any earth moving, construction, or potential dust generating operation. Such written description may be incorporated into building and construction plans or a separate document submitted with said plans.

*Crown* means the cross slope or difference in elevation between the high point of a street (usually the centerline of the street) and the gutter line, adjacent to the pavement edge, for any given cross section. Crown is normally expressed as a percentage.

*Cul-de-sac* means a minor street with only one outlet and culminated by a turnaround.

*Curb cut* means a depressed segment of a vertical roadway curb.

*Curb return* means a curved segment of curb used at each end of an opening in the roadway curb.

*Design storm* means a storm that deposits a stated amount of precipitation within a stated period over a defined area and which is used in calculating storm runoff and in designing drainage control, flood control and erosion control measures.

*Design year* means the year during which the roadway improvements shall reach life expectancy with normal maintenance.

*Development review committee* means an informal group of representatives employed or retained by the city whose duties include reviewing subdivision or subdivision-related proposals and resolving conflicting comments, recommendations or design differences between city reviewing departments and developers. The committee's decision shall be final unless overruled by the planning and zoning commission or board of adjustment or city council.

*Disturbed area* means any area in which the soil will be altered by grading, leveling, scraping, cut and fill activities, excavation, brush and timber clearing, grubbing, and unpaved soils on which vehicle operations and/or movement will or has occurred.

*Double penetration* means, commonly, two or three successive applications of asphaltic material and mineral aggregate.

*Drainage* means storm drainage.

*Drainage course* means a natural watercourse or indenture for the drainage of surface waters.

*Drainage plan* means a plan indicating an on-site drainage proposal, the passage of stormwaters through the development and safe discharge of runoff onto adjacent lands or into storm drainage facilities. Also, a comprehensive analysis of (i) the existing storm drainage conditions of a proposed development, and (ii) the disposal of the increased runoff which is generated by the proposed development.

*Driveway* means a point of vehicular access between a street and an abutting property, and is further defined to include:

- (1) The area between the face of curb and the right-of-way line for streets with curbs.
- (2) The area between the edge of pavement of the outside travel lane and the right-of-way line for strip paved streets.
- (3) The area between the right-of-way line and 15 feet from the right-of-way line toward the street for completely unimproved streets.

*Drought tolerant plants* means plants from the state and other dry areas that can survive on very little water, such as that which falls in Southern New Mexico in normal rainfall years.

*Dust generating operation* means any activity capable of generating fugitive dust, including, but not limited to, activities associated with creating a disturbed area, construction and demolition activities, and the movement of vehicles on unpaved roadways or parking areas.

*Easement* means the right, liberty, advantage or privilege that one individual or entity has in land of another, either express or imputed (utility, grant, or necessity).

*Engineer* means a person who is engaged in the practice of engineering and is qualified to so practice as attested by his legal registration as a professional engineer in the state.

*Erosion* means the transportation of soil particles, or mass movement of soil (mass wasting), by water, wind front leaving, or mechanical means.

*Erosion control* means treatment measures for the prevention of damages due to soil movement and to deposition from the ten-year design storm runoff.

*ETZ* means extraterritorial zone.

*Flood control* means the treatment measures necessary to protect life and property from the 100-year design storm runoff.

*Flood hazard area* means an area subject to inundation from the 100-year design storm runoff.

*Freeway* means a divided multilane highway for through traffic with all crossroads separated in grade and with full control of access.

*Frontage road* means a local street which is parallel to and adjacent to another street, normally a highway or a freeway.

*Fugitive dust* means any particulate matter entrained in the ambient air which is caused from man-made and natural activities without first passing through a stack or duct designed to control flow, including, but not limited to, emissions caused by movement of soil, vehicles, equipment, and windblown dust. Excluded particulate matter includes matter emitted directly from the exhaust of motor vehicles, or from other combustion devices, portable brazing, soldering or welding equipment, and pile drivers.

*Grading plan* means a plan describing the existing topography and proposed grading, including retaining walls and details, interfaces with adjacent properties, streets, alleys and channels, referenced to mean sea level based on a city benchmark, and showing sufficient contours, spot elevations and cross sections to allow a clear understanding by reviewers, contractors and inspectors.

*High wind event* means a climatological occurrence in which the average wind speed exceeds a threshold in which fugitive dust will be generated from undisturbed areas, naturally covered areas, disturbed areas, and construction sites, regardless of reasonably available control measure implementation. Notwithstanding other climatic conditions, the average wind speed for high wind events is a sustained wind speed of 25 miles per hour or greater.

*Hot mix asphaltic concrete* means high-quality, thoroughly controlled hot mixture of asphalt cement and well-graded, high-quality aggregate, thoroughly compacted into a uniform dense mass.

*Improvements* includes infrastructure such as streets; curbs; gutters; sidewalks; fire hydrants; storm drainage facilities; bikepaths; trails; and water, sewer, and gas systems or parts thereof.

*ITE* means Institute of Transportation Engineers.

*Landscaping* means a combination of trees, shrubs, perennials, ground covers and artifacts, arranged in such a manner as to effect a design that follows the principles of this chapter.

*Local street* means a street of relatively short length that provides access to a collector street and is designed to discourage its use by through traffic.

*Lot* means a portion of a subdivision or other parcel of land intended for the purpose of development, whether immediate or future. It also is tract of land described by metes and bounds and held in separate ownership, as shown on the records in the county assessor's office.

*Maintenance* means the cleaning, shaping, grading, repair and minor replacement of drainage, flood control and erosion control facilities, but not including the cost of power consumed in the normal operation of pump stations.

*Major arroyo* means any channel whose watershed exceeds 320 acres in a 100-year design storm, whether such watershed is in its natural or unaltered state or has been altered by development, runoff diversions, or detention facilities.

*Native plants* means plants that are indigenous to the state from other places that have become established in wildlands without cultivation.

*Natural cover* means any vegetation which exists on the property, prior to any construction activity or achieved through vegetation restoration back to a natural state, including the placement of sod.

*One-hundred year design storm* means that storm whose precipitation within a six-hour period and resulting runoff has a one-percent chance of being equaled or exceeded in any given year.

*Ornamental plants* means plants cultivated in this area for landscaping purposes.

*PM10* means particulate matter, both filterable and condensable, with an aerodynamic diameter less than or equal to a nominal ten micrometers.

*Palliative* means any agent used to lessen or reduce dust emissions.

*Parking area* means that portion of a lot, the use of which is devoted to more than four off-street parking spaces.

*Parkway* means that area of a public street that is between the curb and sidewalk or between the sidewalk and the property line, which is used for planting purposes.

*Particulate matter* means any material emitted or entrained into the air as liquid or solid particulate, with the exception of uncombined water.

*Public rights-of-way* means the total area of land deeded, reserved by plat, or otherwise acquired by the city, the county, or the state.

*Reasonably available control measures (RACM)* means techniques used to limit the emission and/or airborne transport of fugitive dust from its original site to accomplish



satisfactory results for temporary and/or extended suppression of dust and PM10 emission(s).

*Roadway* means that portion of the street available for vehicular traffic.

*SCS* means Soil Conservation Service.

*Sidewalk* means a pedestrian walkway with permanently improved surfacing.

*Slope* means an inclined piece of land, three feet or higher vertical rise, with a five horizontal to one vertical incline or greater.

*Street* means a public way that has been dedicated or reserved by plat, other than an alley, which affords the principal means of access to abutting property.

*Street trees* means trees planted in the public right-of-way along city streets for beautification and benefit of the general public.

*Surveyor* means a person who is engaged in the practice of surveying and is qualified to so practice as attested by his legal registration as a professional surveyor in the state.

*Ten-year design storm* means that storm whose precipitation within a six-hour period and resulting runoff has a ten-percent chance of being equaled or exceeded in any given year.

*Topsoil* means soil which is with the A-1 horizon of a soil profile, containing organic matter, nutrients, and the microorganisms necessary for normal plant growth.

*Visible dust emission* means dust of such opacity as to obscure an observer's view to a degree equal to or greater than an opacity of 20 percent, for a period or periods aggregating more than three minutes in any one hour.

*Water conservation* means proper water management procedures, including design as well as maintenance procedures by using drip irrigation, drought tolerant plant materials and gray water.

*Wildlife* means indigenous or naturalized bird, reptilian, mammalian, fish, or invertebrate life found in the out-of-doors.

*Wind speed* means the average wind velocity, regardless of direction, based on a 60-minute average from the nearest weather report or PM10 monitoring station, or by a portable wind instrument located at the site.  
(Ord. No. 949, § 1.6, 9-8-87; Ord. No. 1224, §§ 2, 3, 3-18-91; Ord. No. 1789, § III, 4-3-00)

**Cross References:** Definitions generally, § 1-2.

### **Sec. 32-3. Purpose.**

The design standards in this chapter are to provide for the harmonious development of the city and its environs in order to establish conditions favorable to the health, safety, convenience, and general welfare of citizens of the city. More specifically, this chapter is designed to achieve the following objectives in newly developed areas:

- (1) Adequate provisions for light and air, public rights-of-way, public open spaces, and drainage and private property utilized by the public.
- (2) Economy in governmental expenditure and adequate reimbursement of the city for services performed.
- (3) Safe, convenient circulation of people, goods and vehicles.
- (4) Coordination of land development in accordance with orderly physical patterns as stated in adopted plans and policies as may have been or may be adopted by the city council.

(Ord. No. 949, § 1.2, 9-8-87)

### **Sec. 32-4. Statutory authority and jurisdiction.**

This chapter is created and adopted pursuant to the authority set forth in NMSA 1978, § 3-19-6, as amended, and shall be applicable to all property within the corporate limits of the city, except for state and federal land being used for public purposes, and within the five-mile planning and platting jurisdiction (ETZ) of the city.

(Ord. No. 949, § 1.3, 9-8-87)

### **Sec. 32-5. Interpretation and conflict.**

(a) *Minimum requirements.* The provisions of this chapter shall be considered the minimum requirements to meet the purpose expressed in section 32-3.

(b) *Local conflict.* Where the provisions of any local ordinance, regulation, or covenant imposes greater restrictions than those of this chapter, the provisions of such document shall prevail.

(c) *Federal and state conflict.* Any provision of U.S. or state law, which imposes a greater duty, standard or requirement than that contained in this chapter shall supersede this chapter.

(d) *Interpretation of meaning.* The development review committee shall interpret the meaning of the sections of this chapter. Disagreement with an interpretation may be appealed to the board of adjustment, formerly known as the code enforcement board of appeals, and the board's decision may be appealed to the city council.

(e) *Conflict within this chapter.* When two or more provisions of this chapter are conflicting, the most restrictive provision shall apply.  
(Ord. No. 949, § 1.5, 9-8-87; Ord. No. 1224, § 1, 3-18-91)

**Sec. 32-6. Violations; penalties.**

(a) *Violations.* The definition of "violation of this Code" set out in subsection 1-10(a) is hereby adopted to apply to acts or failures to act in accordance with the requirements of this Code and such definition is incorporated in this section by reference as if set out in full at this place.

(b) *Penalties.* The municipal court may impose a fine for each offense, not to exceed \$300.00, for each day the violation is found to have occurred. In addition to any fines thus imposed, the municipal court is authorized to issue orders of the court to remove structures or take other actions to abate, remove or bring into compliance any violation of this chapter. Failure to comply with any such orders for removal or other judgments of the municipal court, including failure to pay fines previously imposed, shall constitute a contempt of court and may be separately punished at the discretion of the municipal court.

(c) *Other remedies.* Nothing in this section shall limit the city from seeking other remedies at law or equity to enforce this chapter.  
(Ord. No. 1158, § 1.6.A--C, 7-2-90)

**Secs. 32-7--32-35. Reserved.**

**ARTICLE II.**

**STANDARDS FOR PUBLIC RIGHTS-OF-WAY**

**Sec. 32-36. City streets.**

(a) *Purpose of this article.* The purpose of article II is to provide information for the establishment of public rights-of-way. This involves right-of-way requirements and general design specifications for city streets, design criteria for sidewalks, and specifications for the installation of street lights. General information regarding utility improvements is also provided. These shall be considered the minimum standards and nothing shall prevent the engineering review committee or the development review committee from imposing greater standards to achieve the purposes outlined in section 32-3 of these design standards.

(b) *Right-of-way and roadway requirements for city streets.* It shall be the policy of the city that major thoroughfares, collectors and arterials with medians, be built from the outside edge of the right-of-way in towards the center. This prevents the dismantling of previously constructed infrastructure in order to accommodate future street improvements such as widening. The location of collector and arterial streets shall

be generally guided by the MPO transportation plan and specifically located as development occurs. Coordination between the city staff, development review committee and the developer will occur to provide the appropriate classification and alignment of all major and minor roadways within and abutting developments to encourage appropriate and efficient transportation circulation patterns.

A subdivider shall be responsible for 100% of the street improvements within the boundaries of the subdivision. When improvements are required on streets adjacent to a subdivision or property boundaries as indicated by street classification, as determined by the MPO transportation plan, transportation element of the comprehensive plan and/or the development review committee, the subdivider shall provide the following street improvements or pay for the cost of these improvements to the city:

Adjacent Street Classification	Street Improvement Requirements
Low Density Local	full street section
Minor Local	full street section
Major Local	1/2 street section, including sidewalk, curb and gutter
Collector	1/2 street section, including sidewalk, curb and gutter
Minor Arterial	1/2 street section, including sidewalk, curb and gutter
Major Arterial	1/2 street section, including sidewalk, curb and gutter

Access requirements for subdivisions shall consist of the following:

- (1) Minimum access to the subdivision shall be from a dedicated and accepted public right-of-way. In instances where the access to a subdivision of is unimproved it shall be the responsibility of the subdivider to construct a minor local roadway from the subdivision boundary to the nearest paved public roadway. If the roadway to the proposed development is classified as a major thoroughfare by the MPO transportation plan (e.g., a collector or arterial), the developer shall provide the equivalent of a minor local roadway, designed and constructed to a cross section approved by the city from the boundary of the subdivision to the nearest paved public roadway.
- (2) Access to lots within a commercial or industrial subdivision shall be from either a dedicated and accepted improved public right-of-way or an improved access established by a 50 foot (15.24m) wide permanent private road and/or access easement. Exceptions to allow a narrower lot access may be considered by the DRC.



- (3) Access to lots within a residential subdivision shall be from a dedicated and accepted improved public right-of-way.

All developing parcels of real property shall include a minimum of 50 percent of the necessary additional right-of-way to conform to the MPO transportation plan for all roads classified major local and above. 100 percent of the required right-of-way shall be required for low density and minor local streets. A permanent right-of-way easement may be granted in lieu of dedicated right-of-way. The decision to accept a permanent easement in lieu of dedicated right-of-way rests with the development review committee. The development review committee may waive all additional right-of-way requirements in instances where expansion of a specific roadway is neither feasible nor planned.

The following cross-section (14 pages) provide the requirements for right-of-way, paving width, parkways, and general use criteria for all acceptable city street classifications. Deviations or modifications to design may be acquired through the engineering review committee.

THIS SPACE INTENTIONALLY LEFT BLANK

# LOW DENSITY LOCAL - 1

**R.O.W. WIDTH:** 40 FT. (12.19M)  
**DESIGN SPEED:** 25mph (40kph)

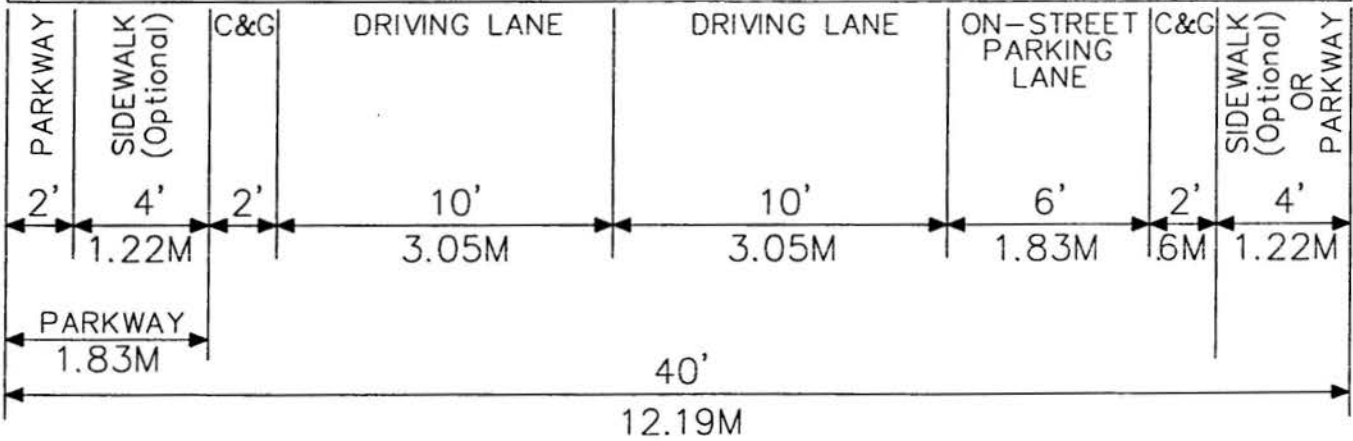
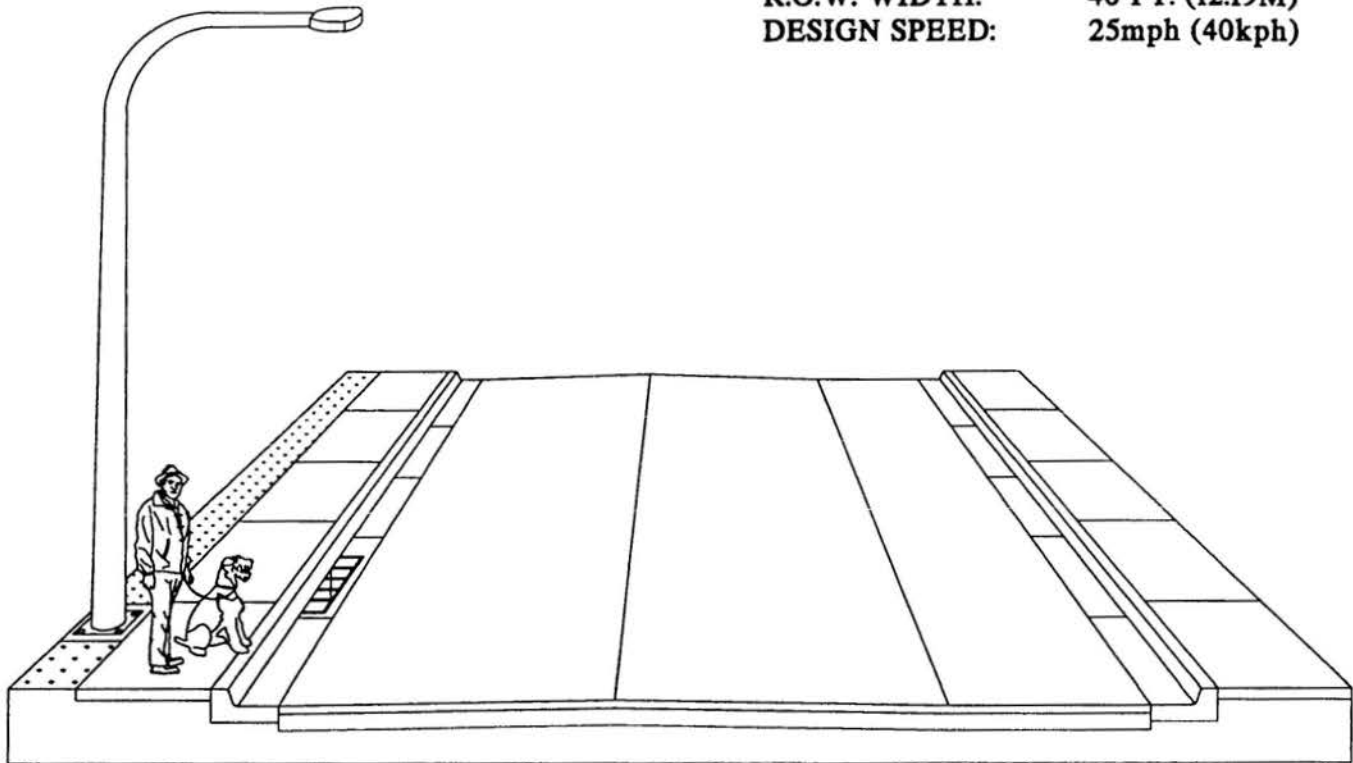

- NOTES:
1. ALLOWED IN ZONING DISTRICTS WHERE MINIMUM LOT SIZE IS 0.5 ACRE & GREATER.
  2. FIVE (5) OFFSTREET PARKING SPACES ARE REQUIRED PER LOT.
  3. AVERAGE DAILY TRAFFIC SHALL NOT EXCEED 250 FOR THIS STREET CLASSIFICATION.
  4. 6' PARKWAY RESERVED FOR POSSIBLE FUTURE INSTALLATION OF A 4' SIDEWALK WITH THE REMAINING 2' PARKWAY USED FOR STREET FURNITURE.
  5. PARKING ALLOWED ON THE EAST SIDE OF NORTH/SOUTH STREETS AND NORTH SIDE OF EAST/WEST STREETS.
  6. ONLY TYPE A, B, C, OR D CURB & GUTTER SHALL BE INSTALLED.
  7. SIGNAGE AND PAVEMENT MARKINGS SHALL BE REQUIRED IN ACCORDANCE WITH THE MUTCD.

# LOW DENSITY LOCAL - 2

R.O.W. WIDTH: 40 FT. (12.19M)  
 DESIGN SPEED: 25mph (40kph)

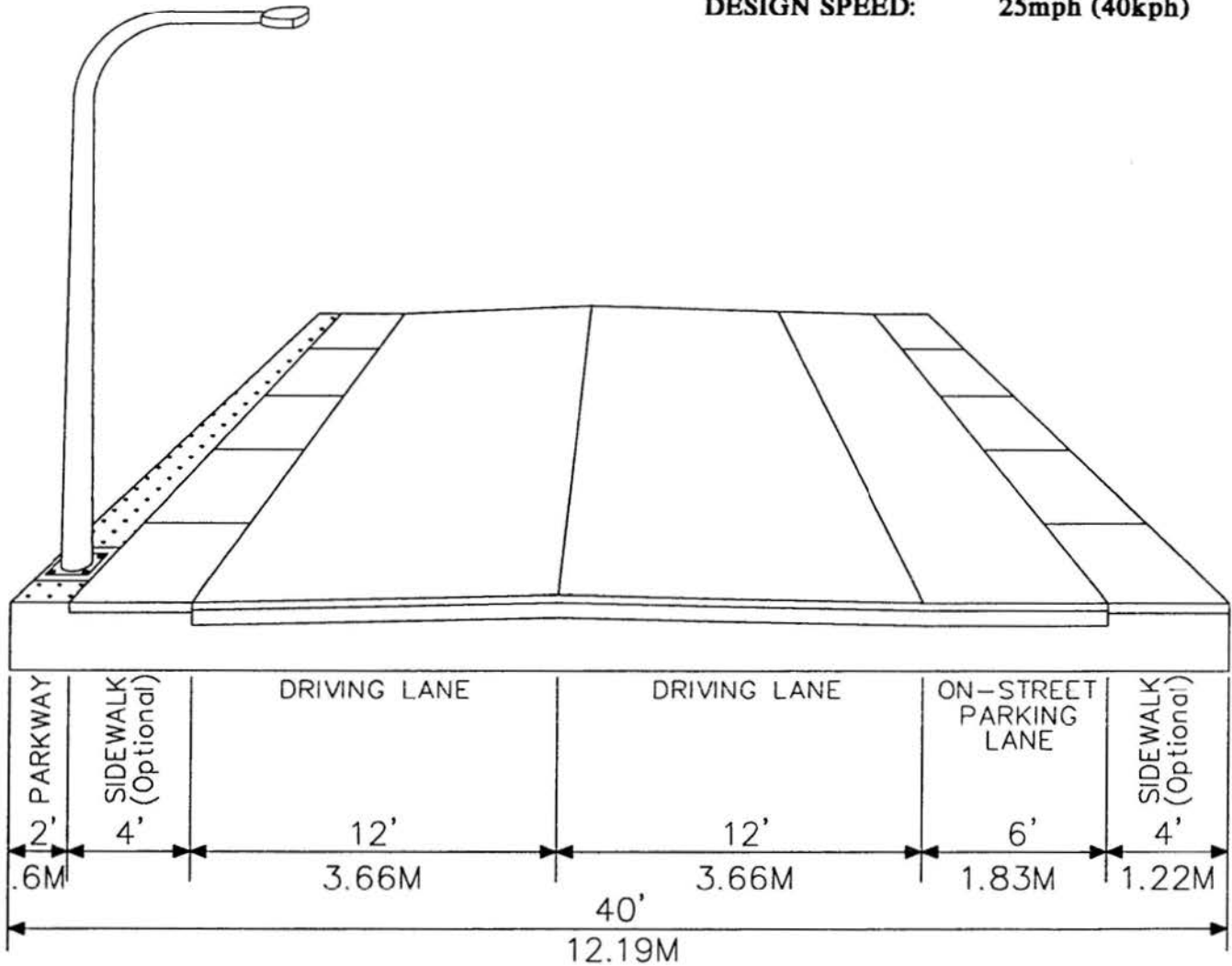

- NOTES:
1. ALLOWED IN ZONING DISTRICTS WHERE MINIMUM LOT SIZE IS 0.5 ACRE & GREATER.
  2. FIVE (5) OFFSTREET PARKING SPACES ARE REQUIRED PER LOT.
  3. REQUIRED DRAINAGE EASEMENT IN FRONT OF EACH LOT AS OUTLINED IN THE DRAINAGE REPORT AND SUBDIVISION PLAT.
  4. AVERAGE DAILY TRAFFIC SHALL NOT EXCEED 250 PER DAY FOR THIS STREET CLASSIFICATION.
  5. PARKING ALLOWED ON THE EAST SIDE OF NORTH/SOUTH STREETS AND NORTH SIDE OF EAST WEST STREETS.
  6. EITHER SIDEWALK OR TYPE "J" HEADER CURB, MUST BE PROVIDED.
  7. FOR SIDEWALKS, SEE SECTION 2.2 SIDEWALK REQUIREMENTS.
  8. CROSS-SLOPE FROM ROADWAY TO SWALE SHALL BE A MAXIMUM OF 2%. SWALE REQUIREMENTS ARE OUTLINED IN SECTION 3.1C.
  9. DRAINAGE SWALES MUST BE BUILT OUTSIDE OF RIGHT-OF-WAY.

# MINOR LOCAL - 1

## ON-STREET PARKING WITH NO CURB & GUTTER

R.O.W. WIDTH: 50 FT. (15.24M)  
 DESIGN SPEED: 25mph (40kph)

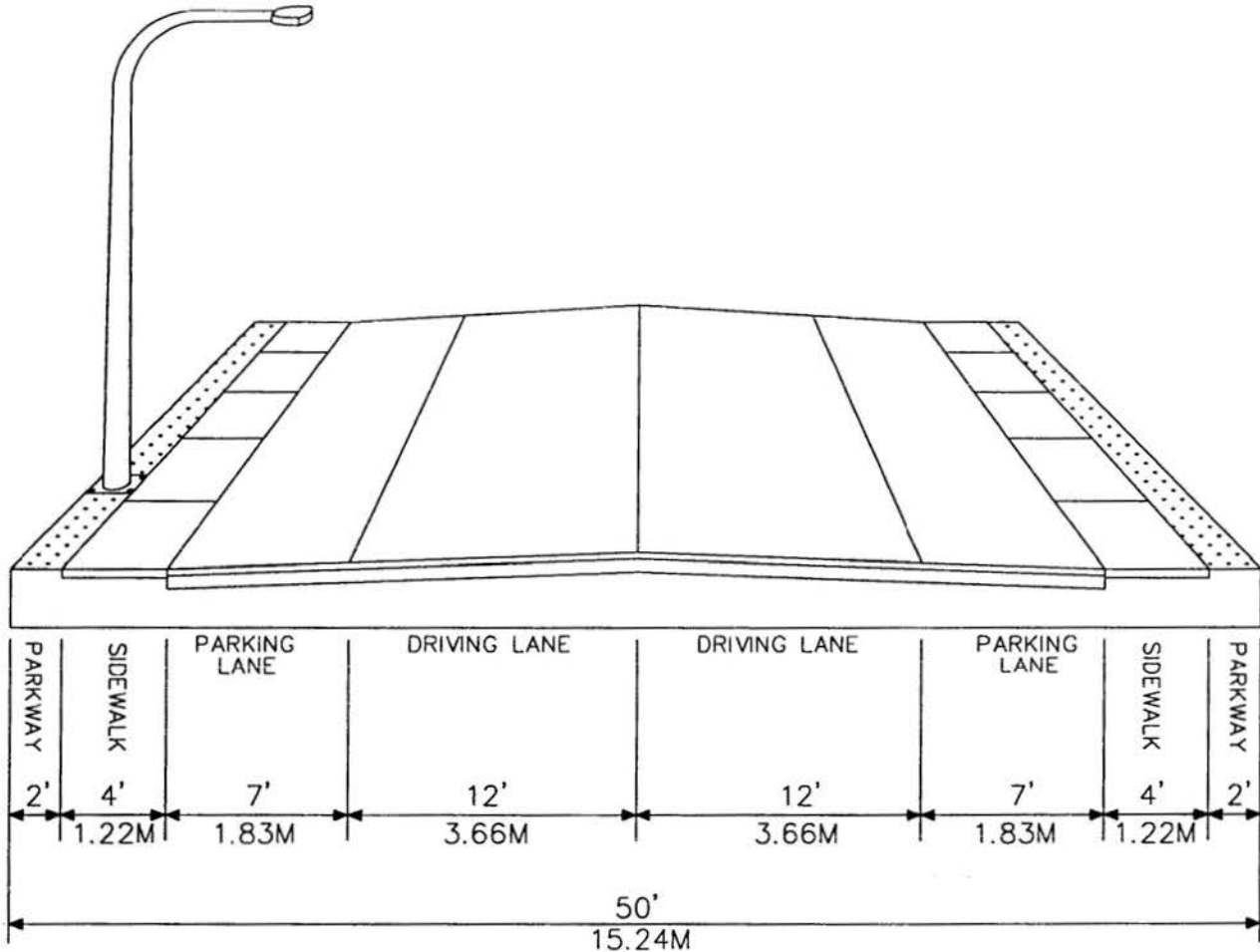

- NOTES:
1. REQUIRED DRAINAGE EASEMENT IN FRONT OF EACH LOT AS OUTLINED BY THE DRAINAGE REPORT AND SUBDIVISION PLAT.
  2. FOR SIDEWALKS, SEE SECTION 2.2 SIDEWALK REQUIREMENTS.
  3. CROSS-SLOPE FROM ROADWAY TO SWALE SHALL BE A MAXIMUM OF 2%. SWALE REQUIREMENTS ARE OUTLINED IN SECTION 3.1C.
  4. DRAINAGE SWALES MUST BE BUILT OUTSIDE OF RIGHT-OF-WAY.
  5. SIGNAGE AND PAVEMENT MARKINGS WILL BE REQUIRED IN ACCORDANCE WITH THE MUTCD.



# MINOR LOCAL - 2

## ON-STREET PARKING WITH CURB & GUTTER

R.O.W. WIDTH: 50 FT. (15.24M)  
 DESIGN SPEED: 25mph (40kph)

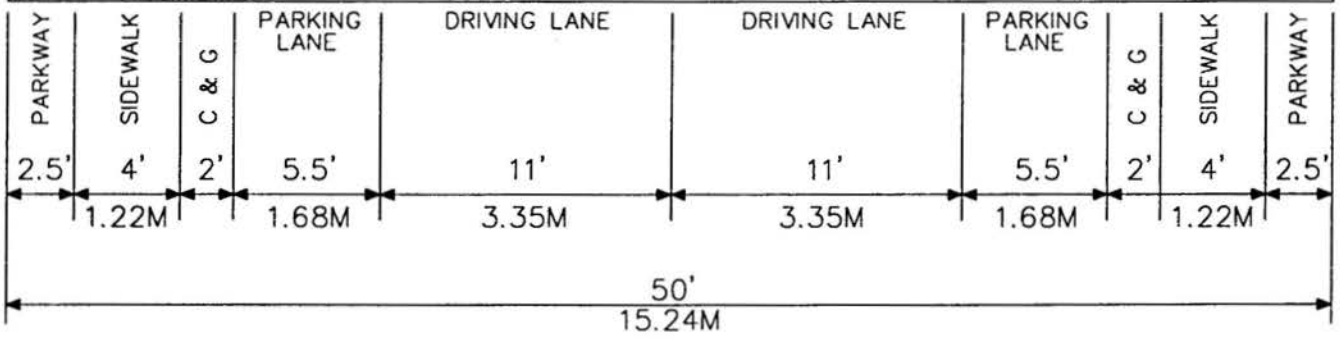
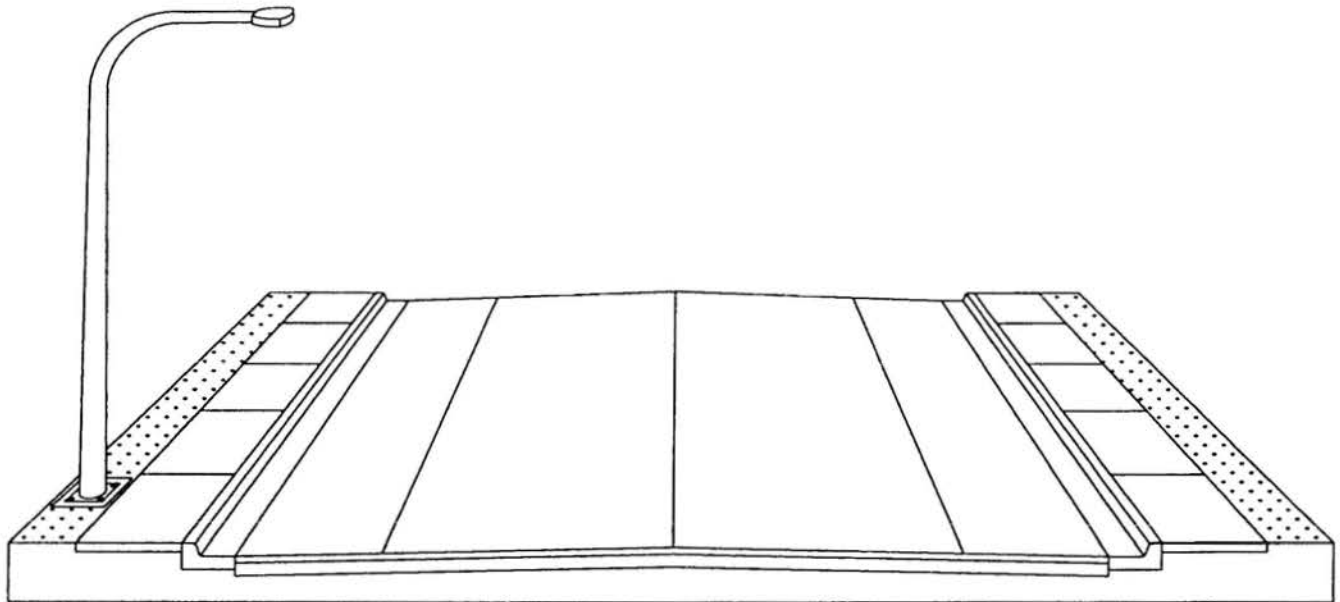

- NOTES:
1. ALL CURB RETURNS SHALL BE STAND UP CURB & GUTTER (TYPE A, B, C, or D).
  2. SIDEWALKS SHALL BE CONSTRUCTED ACCORDING TO SECTION 2.2 SIDEWALK REQUIREMENTS.
  3. SIGNAGE AND PAVEMENT MARKINGS SHALL BE REQUIRED IN ACCORDANCE WITH THE MUTCD.

# MAJOR LOCAL - 1

## 3 LANE WITH NO PARKING

R.O.W. WIDTH: 60 FT. (18.28M)  
 DESIGN SPEED: 30mph (45kph)

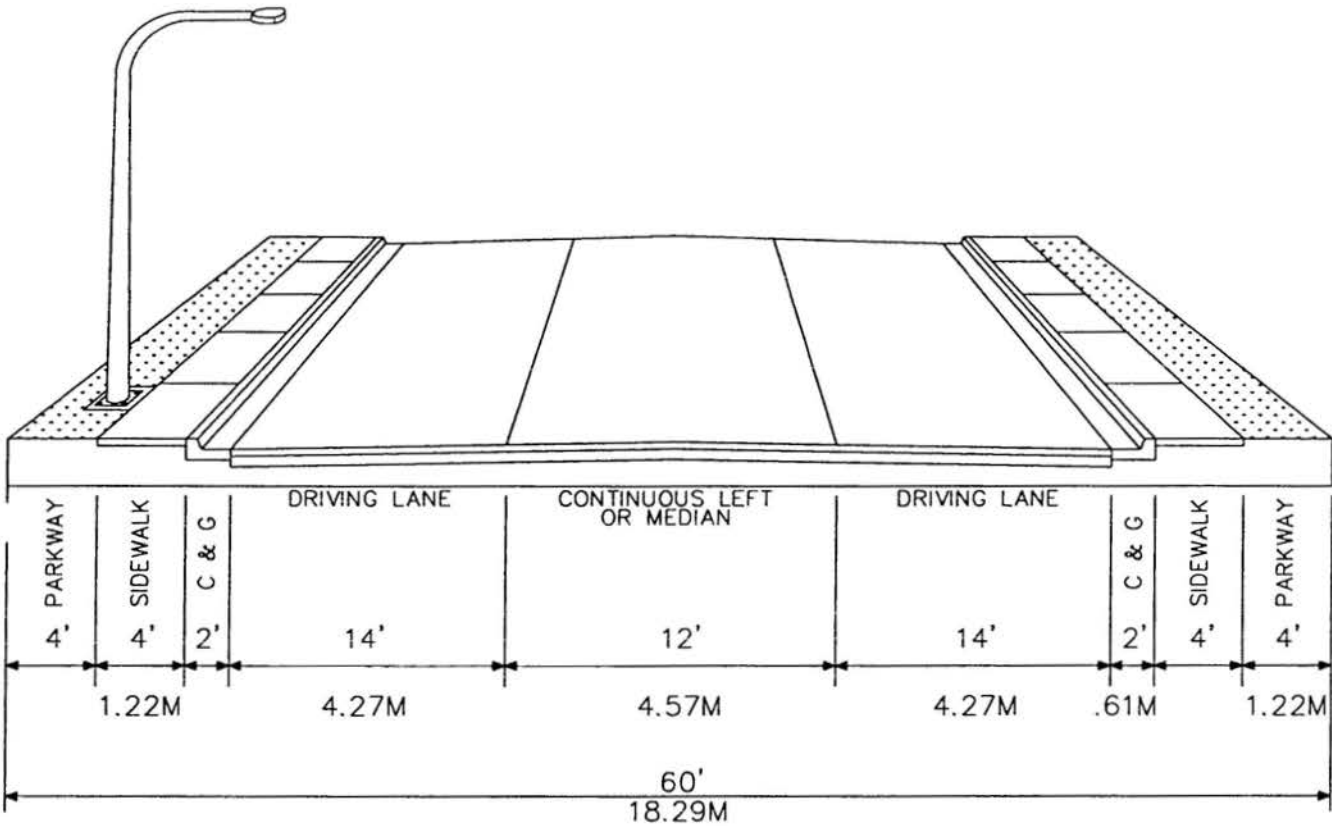

- NOTES:
1. DRIVING LANE WIDTHS MAY VARY WITH ENGINEERING REVIEW COMMITTEE (ERC) APPROVAL.
  2. NO ON STREET PARKING SIGNAGE SHALL BE REQUIRED.
  3. MINIMUM STREET CLASSIFICATION WITH COMMERCIAL OR INDUSTRIAL ZONING ON EITHER OR BOTH SIDES OF THE RIGHT-OF-WAY.
  4. PARKWAY MAY BE USED BY THE ADJACENT LAND OWNER FOR LANDSCAPING. UP TO 1/3 OF THE REQUIRED LANDSCAPING MAY BE PLACED WITHIN THE RIGHT-OF-WAY.
  5. ALL CURB RETURNS SHALL BE STAND UP CURB & GUTTER (TYPE A, B, C, OR D).
  6. IF MEDIANS ARE CONSTRUCTED, TYPE "K" OR TYPE "L" CURB & GUTTER MUST BE USED.
  7. SIGNAGE AND PAVEMENT MARKINGS WILL BE REQUIRED IN ACCORDANCE WITH THE MUTCD.
  8. SIDEWALKS SHALL BE CONSTRUCTED ACCORDING TO SECTION 2.2 SIDEWALK REQUIREMENTS.

# MAJOR LOCAL - 2

## 2 LANE WITH ON-STREET PARKING OR BIKE LANE

**R.O.W. WIDTH: 60 FT. (18.28M)**  
**DESIGN SPEED: 30mph (45kph)**

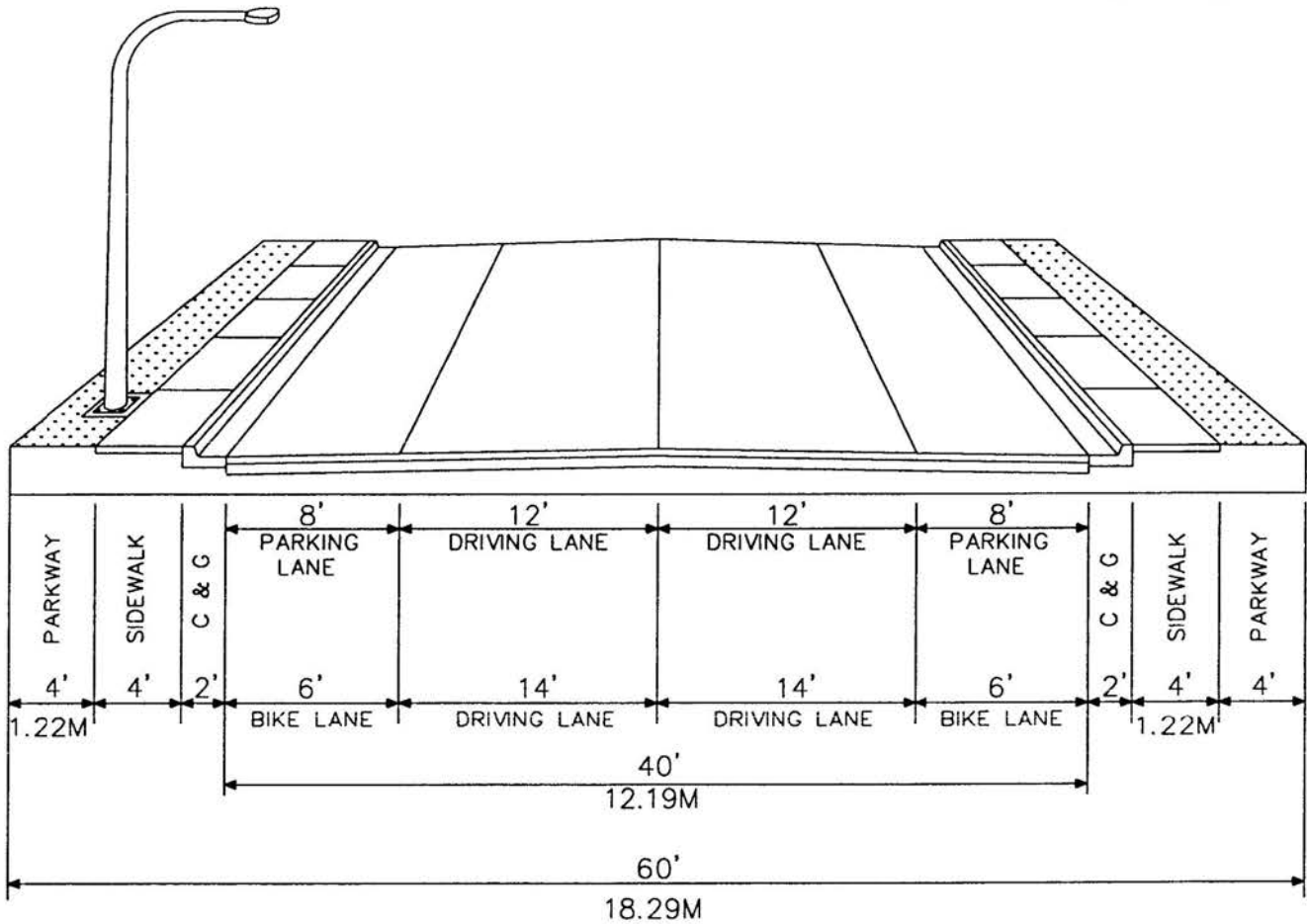

- NOTES:
1. DRIVING AND PARKING LANES MAY VARY WITH ENGINEERING REVIEW COMMITTEE (ERC) APPROVAL.
  2. A BIKE LANE SHALL BE CONSTRUCTED WHEN REQUIRED BY THE BICYCLE FACILITIES & SYSTEMS MASTER PLAN AND "NO PARKING" SIGNS WILL BE REQUIRED.
  3. MINIMUM STREET CLASSIFICATION WITH COMMERCIAL OR INDUSTRIAL ZONING ON EITHER OR BOTH SIDES OF THE RIGHT-OF-WAY.
  4. PARKWAY MAY BE USED BY THE ADJACENT LAND OWNER FOR LANDSCAPING. UP TO 1/3 OF THE REQUIRED LANDSCAPING MAY BE PLACED WITHIN THE RIGHT-OF-WAY.
  5. ALL CURB RETURNS SHALL BE STAND UP CURB & GUTTER (TYPE A, B, C, OR D).
  6. SIGNAGE AND PAVEMENT MARKINGS WILL BE REQUIRED IN ACCORDANCE WITH THE MUTCD.
  7. SIDEWALKS SHALL BE CONSTRUCTED ACCORDING TO SECTION 2.2 SIDEWALK REQUIREMENTS/OPTIONS.

# COLLECTOR - 1

R.O.W. WIDTH: 85 FT. (25.91M)  
 DESIGN SPEED: 35mph (55kph)

## NO BICYCLE FACILITIES

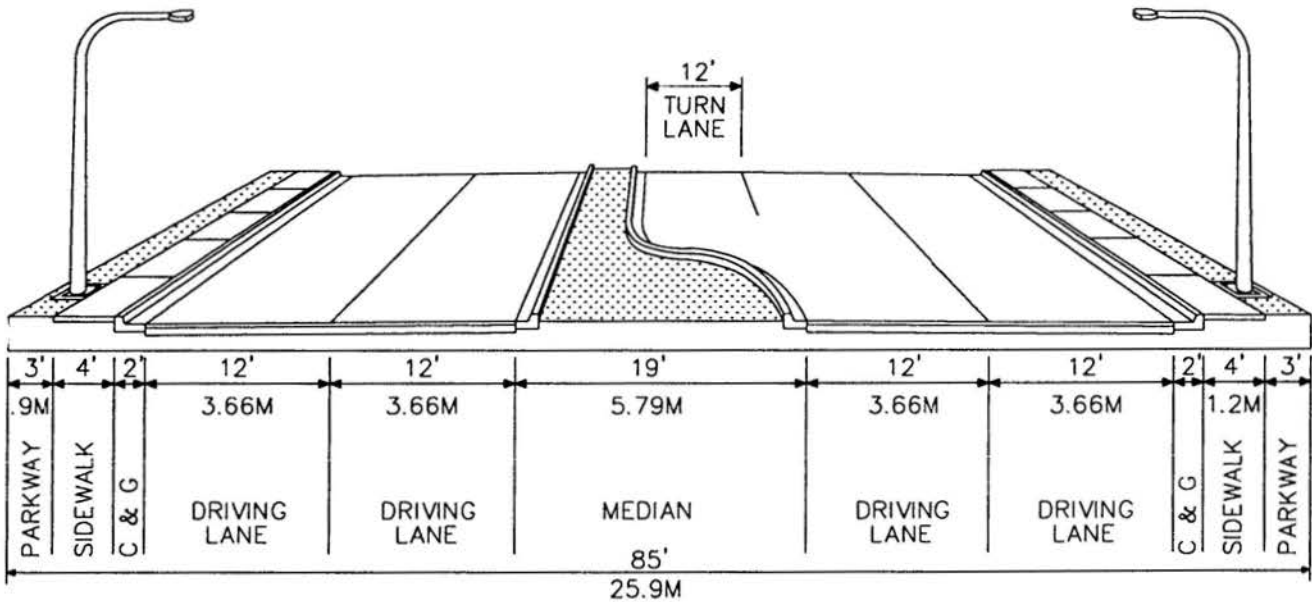

- NOTES:
1. THE DEVELOPER IS RESPONSIBLE FOR EXTENDING FULL SERVICE WATER SUBOUTS AND ELECTRICAL CONDUIT FOR LANDSCAPING IN EACH MEDIAN AND THE PARKWAYS.
  2. PARKWAY MAY BE USED BY THE ADJACENT LAND OWNER FOR LANDSCAPING. UP TO 1/3 OF THE REQUIRED LANDSCAPING MAY BE PLACED WITHIN THE RIGHT-OF-WAY.
  3. MEDIAN CURB & GUTTER, "TYPE K" OR "TYPE L", SHALL BE INSTALLED IN THE MEDIAN.
  4. SIGNAGE AND PAVEMENT MARKINGS WILL BE REQUIRED IN ACCORDANCE WITH MUTCD.



# COLLECTOR - 2

R.O.W. WIDTH: 85 FT. (25.91M)

DESIGN SPEED: 35mph (55kph)

## BIKE LANE OPTION

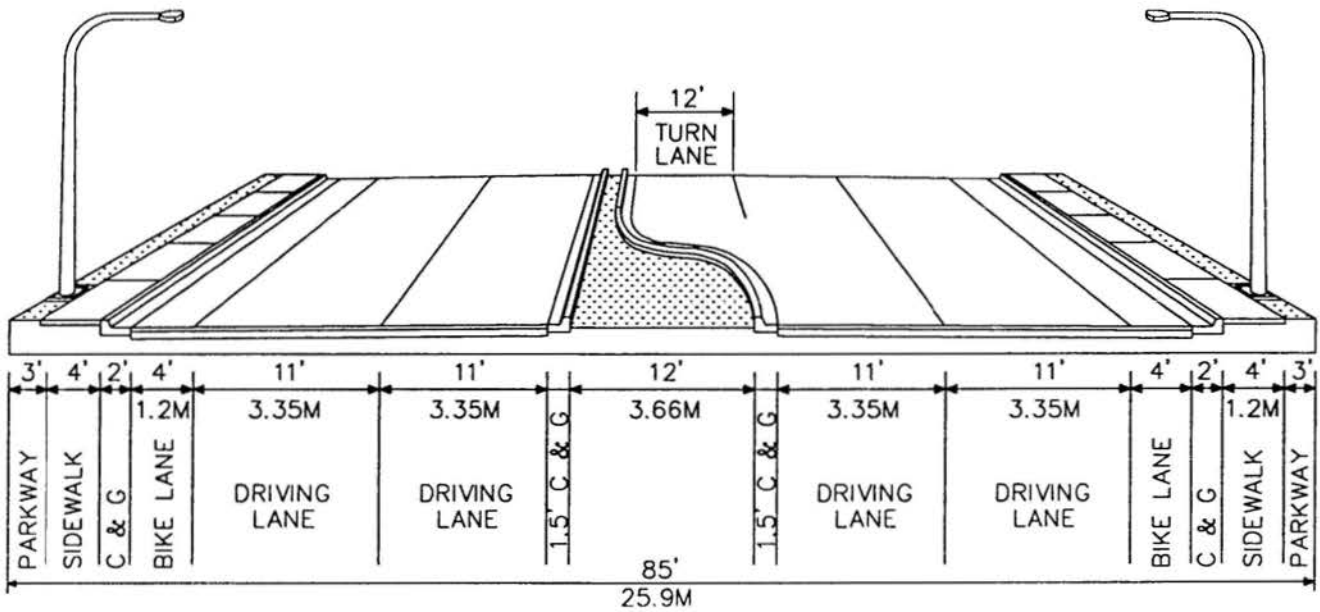

- NOTES:
1. THE DEVELOPER IS RESPONSIBLE FOR EXTENDING FULL SERVICE WATER STUBOUTS AND ELECTRICAL CONDUIT FOR LANDSCAPING IN EACH MEDIAN AND THE PARKWAYS.
  2. PARKWAY MAY BE USED BY THE ADJACENT LAND OWNER FOR LANDSCAPING. UP TO 1/3 OF THE REQUIRED LANDSCAPING MAY BE PLACED WITHIN THE RIGHT-OF-WAY.
  3. A BIKE LANE SHALL BE CONSTRUCTED WHEN REQUIRED BY THE BICYCLE FACILITIES & SYSTEMS MASTER PLAN.
  4. MEDIAN CURB & GUTTER, "TYPE K" OR "TYPE L", SHALL BE INSTALLED IN THE MEDIAN.
  5. SIDEWALKS SHALL BE CONSTRUCTED ACCORDING TO SECTION 2.2 SIDEWALK REQUIREMENTS.
  6. SIGNAGE AND PAVEMENT MARKINGS WILL BE REQUIRED IN ACCORDANCE WITH MUTCD.

# COLLECTOR - 3

R.O.W. WIDTH: 85 FT. (25.91M)  
 DESIGN SPEED: 35mph (55kph)

## NO BICYCLE FACILITIES

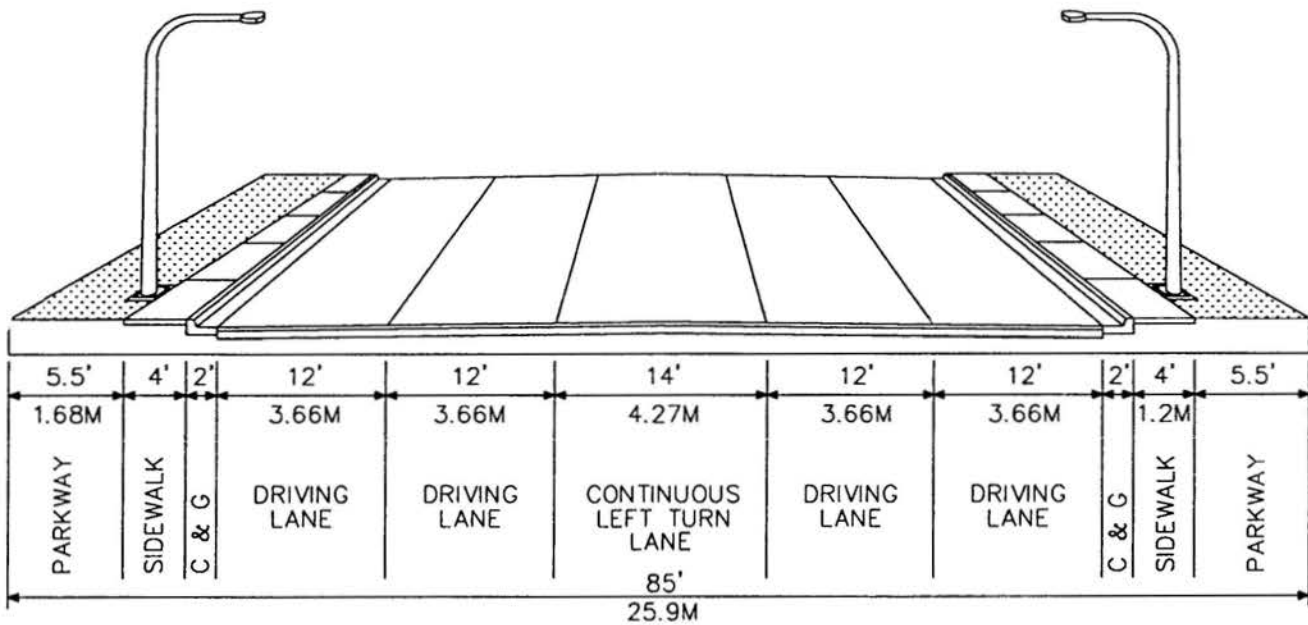

- NOTES:
1. THE DEVELOPER IS RESPONSIBLE FOR EXTENDING WATER STUBOUTS AND ELECTRICAL CONDUIT FOR LANDSCAPING IN PARKWAYS.
  2. PARKWAY MAY BE USED BY THE ADJACENT LAND OWNER FOR LANDSCAPING. UP TO 1/3 OF THE REQUIRED LANDSCAPING MAY BE PLACED WITHIN THE RIGHT-OF-WAY.
  3. SIDEWALKS SHALL BE CONSTRUCTED ACCORDING TO SECTION 2.2 SIDEWALK REQUIREMENTS.
  4. SIGNAGE AND PAVEMENT MARKINGS WILL BE REQUIRED IN ACCORDANCE WITH MUTCD.

# COLLECTOR - 4

R.O.W. WIDTH: 85 FT. (25.91M)

DESIGN SPEED: 35mph (55kph)

## BIKE LANE OPTION

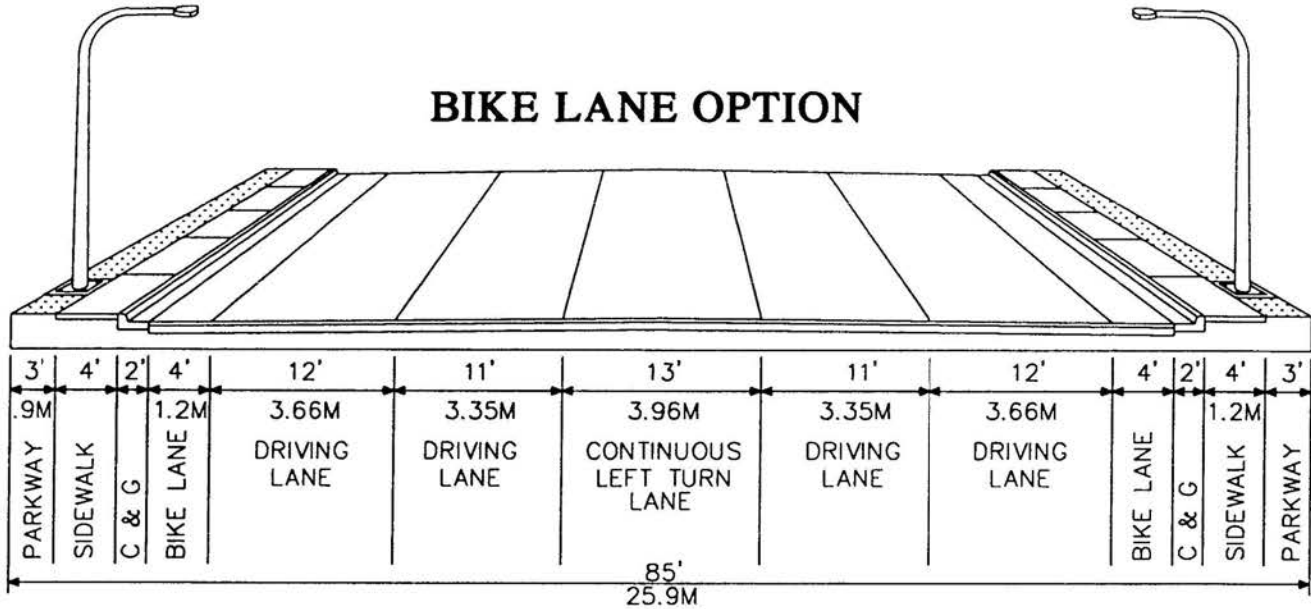

## MULTI-USE PATH OPTION

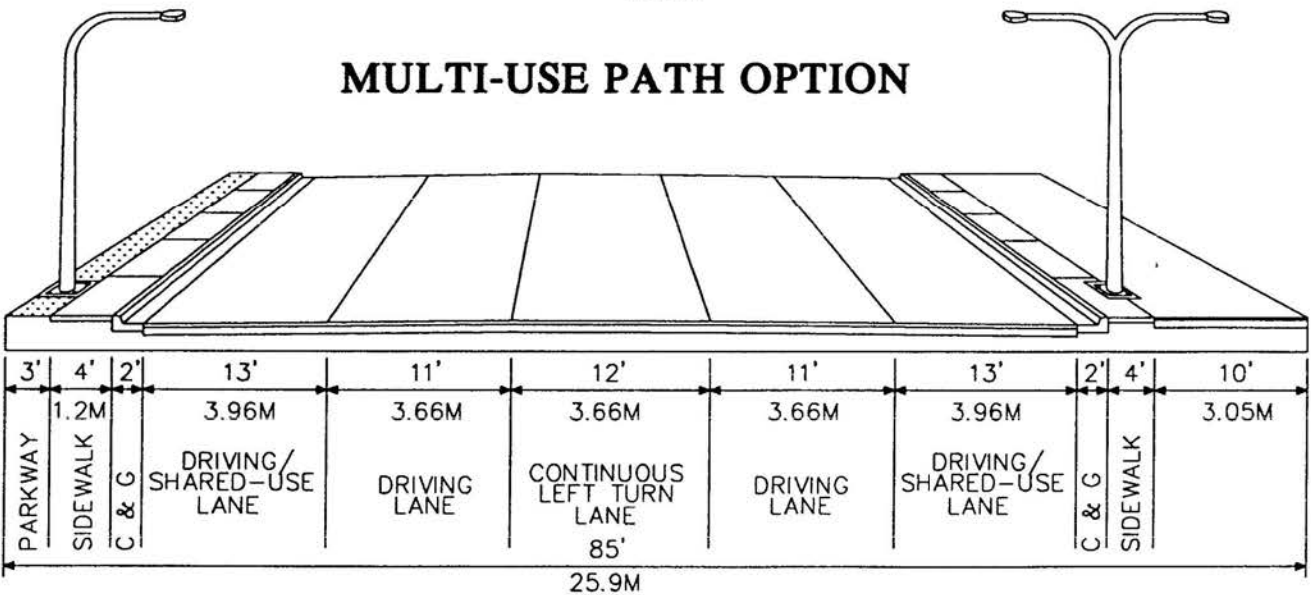

- NOTES:
1. THE DEVELOPER IS RESPONSIBLE FOR EXTENDING WATER STUBOUTS AND ELECTRICAL CONDUIT FOR LANDSCAPING IN PARKWAYS.
  2. PARKWAY MAY BE USED BY THE ADJACENT LAND OWNER FOR LANDSCAPING. UP TO 1/3 OF THE REQUIRED LANDSCAPING MAY BE PLACED WITHIN THE RIGHT-OF-WAY.
  3. WHEN A BIKE PATH IS CONSTRUCTED, THE PAVEMENT SECTION WILL NOT BE CENTERED ON THE RIGHT-OF-WAY.
  4. A MULTI-USE PATH/BIKE LANE SHALL BE CONSTRUCTED WHEN REQUIRED BY THE BICYCLE FACILITIES

# MINOR ARTERIAL - 1

R.O.W. WIDTH: 100 FT. (30.48M)  
 DESIGN SPEED: 45mph (72kph)

## NO BICYCLE FACILITIES

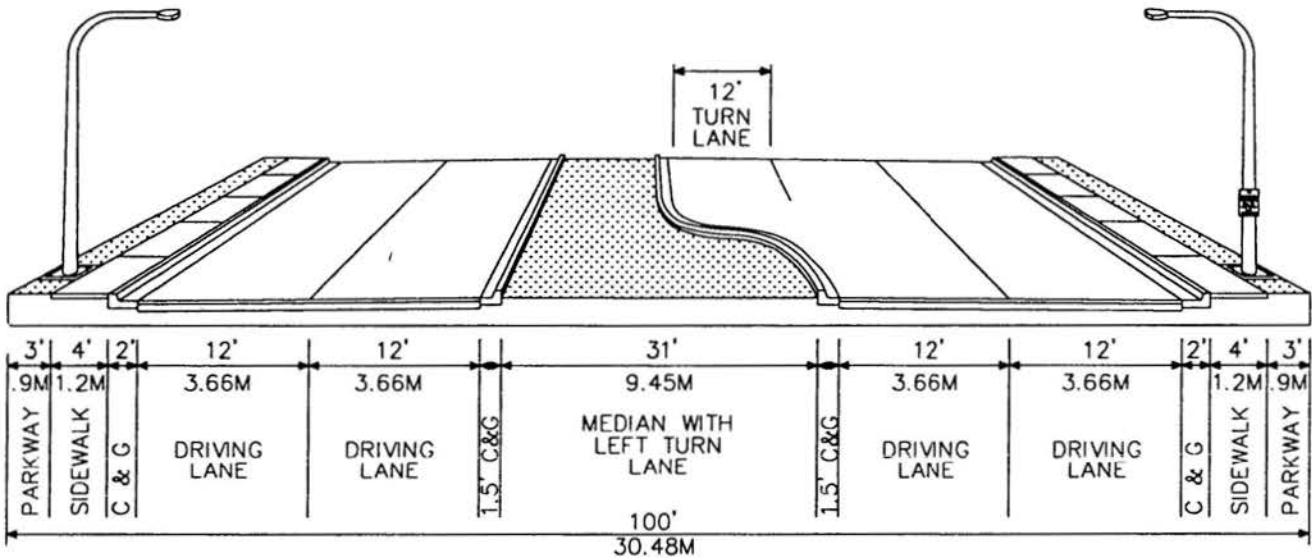

- NOTES:
1. THE DEVELOPER IS RESPONSIBLE FOR EXTENDING FULL SERVICE WATER STUBOUTS AND ELECTRICAL CONDUIT FOR LANDSCAPING IN EACH MEDIAN AND THE PARKWAYS.
  2. PARKWAY MAY BE USED BY THE ADJACENT LAND OWNER FOR LANDSCAPING. UP TO 1/3 OF THE REQUIRED LANDSCAPING MAY BE PLACED WITHIN THE RIGHT-OF-WAY.
  3. SIGNAGE AND PAVEMENT MARKINGS SHALL BE REQUIRED IN ACCORDANCE WITH MUTCD.
  4. MEDIAN CURB & GUTTER, "TYPE K" OR "TYPE L", SHALL BE INSTALLED IN THE MEDIAN.
  5. SIDEWALKS SHALL BE CONSTRUCTED ACCORDING TO SECTIONS 2.2 SIDEWALK REQUIREMENTS.



# MINOR ARTERIAL - 2

R.O.W. WIDTH: 100 FT. (30.48M)  
 DESIGN SPEED: 45mph (72kph)

## BIKE LANE OPTION

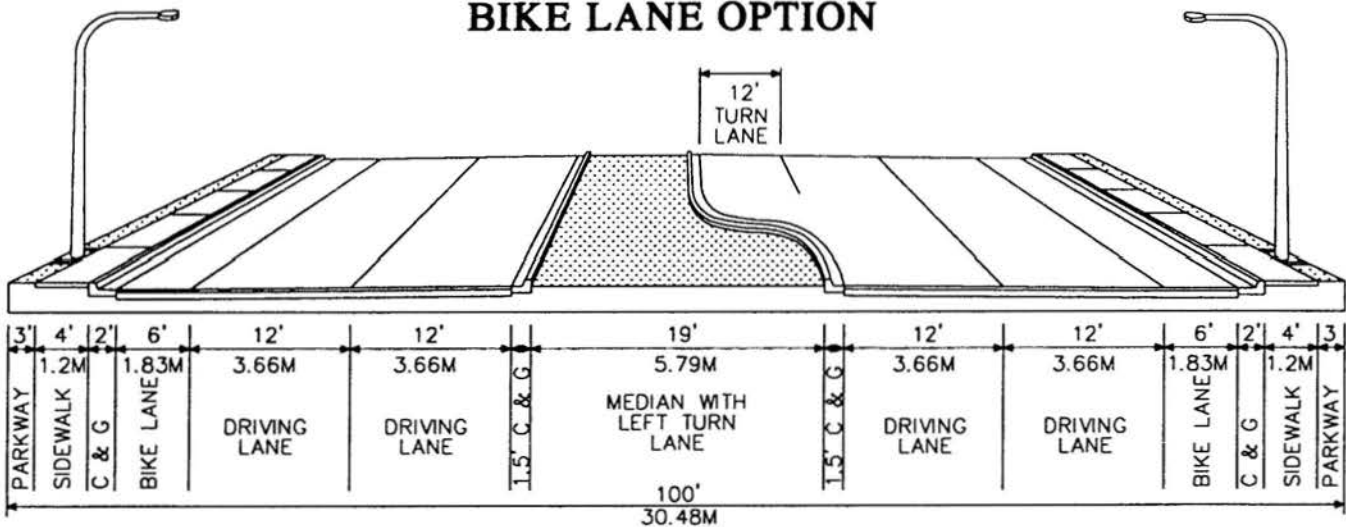

## MULTI-USE PATH OPTION

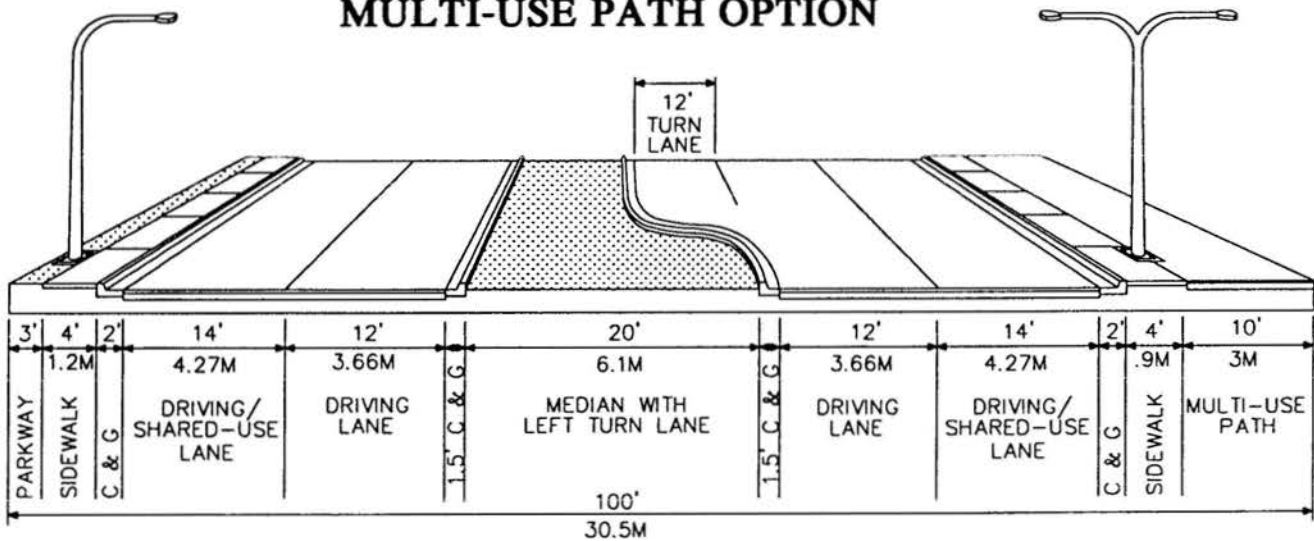

- NOTES:
1. THE DEVELOPER IS RESPONSIBLE FOR EXTENDING FULL SERVICE WATER STUBOUTS AND ELECTRICAL CONDUIT FOR LANDSCAPING IN EACH MEDIAN AND THE PARKWAYS.
  2. PARKWAY MAY BE USED BY THE ADJACENT LAND OWNER FOR LANDSCAPING. UP TO 1/3 OF THE REQUIRED LANDSCAPING MAY BE PLACED WITHIN THE RIGHT-OF-WAY.
  3. A MULTI-USE PATH OR BIKE LANE SHALL BE CONSTRUCTED WHEN REQUIRED BY THE BICYCLE FACILITIES & SYSTEMS MASTER PLAN.
  4. SIGNAGE AND PAVEMENT MARKINGS WILL BE REQUIRED IN ACCORDANCE WITH MUTCD.
  5. MEDIAN CURB & GUTTER, "TYPE K" OR "TYPE L", SHALL BE INSTALLED IN THE MEDIAN.
  6. MULTI-USE PATHS SHALL BE CONSTRUCTED ON THE NORTH SIDE OF EAST/WEST ROADS AND ON THE EAST SIDE OF NORTH/SOUTH ROADS.
  7. SIDEWALKS SHALL BE CONSTRUCTED ACCORDING TO SECTION 2.2 SIDEWALK REQUIREMENTS.

# MAJOR ARTERIAL - 1

R.O.W. WIDTH: 120 FT. (36.58M)  
 DESIGN SPEED: 45mph (72kph)

## NO BICYCLE FACILITIES

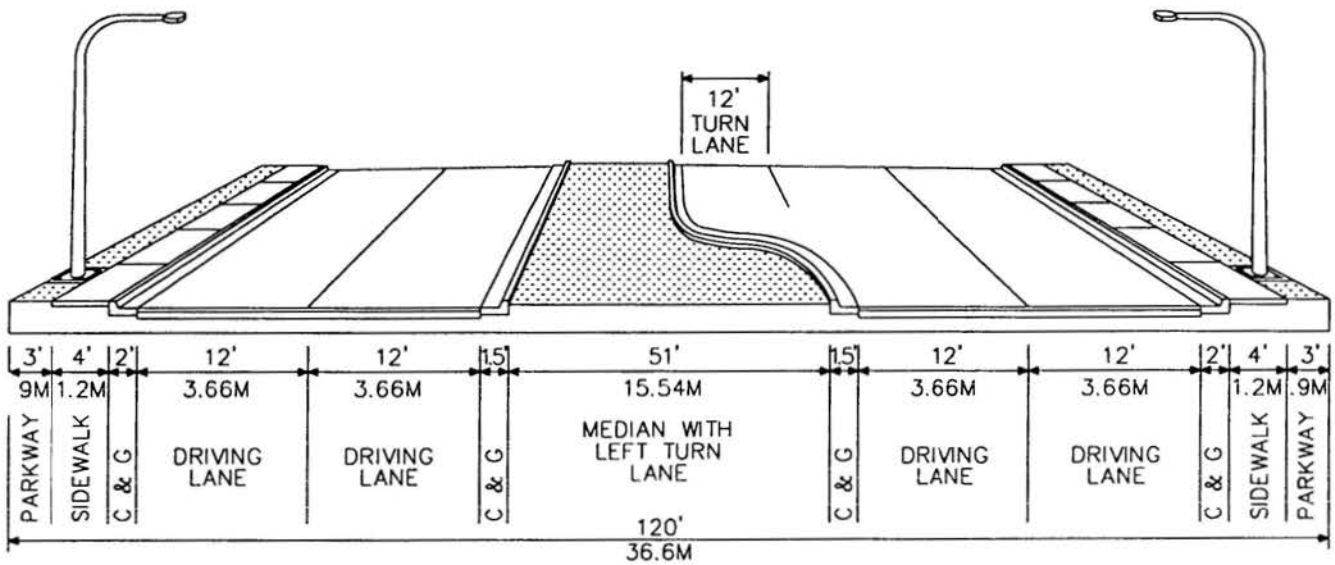

- NOTES:
1. THE DEVELOPER IS RESPONSIBLE FOR EXTENDING FULL SERVICE WATER STUBOUTS AND ELECTRICAL CONDUIT FOR LANDSCAPING IN EACH MEDIAN AND IN THE PARKWAYS.
  2. PARKWAY MAY BE USED BY THE ADJACENT LAND OWNER FOR LANDSCAPING. UP TO 1/3 OF THE REQUIRED LANDSCAPING MAY BE PLACED WITHIN THE RIGHT-OF-WAY.
  3. SIGNAGE AND PAVEMENT MARKINGS WILL BE REQUIRED IN ACCORDANCE WITH MUTCD.
  4. MEDIAN CURB & GUTTER, "TYPE K" OR "TYPE L", SHALL BE INSTALLED IN THE MEDIAN.
  5. SIDEWALKS SHALL BE CONSTRUCTED ACCORDING TO SECTION 2.2 SIDEWALK REQUIREMENTS.

# MAJOR ARTERIAL - 2

R.O.W. WIDTH: 120 FT. (36.58M)  
 DESIGN SPEED: 45mph (72kph)

## BIKE LANE OPTION

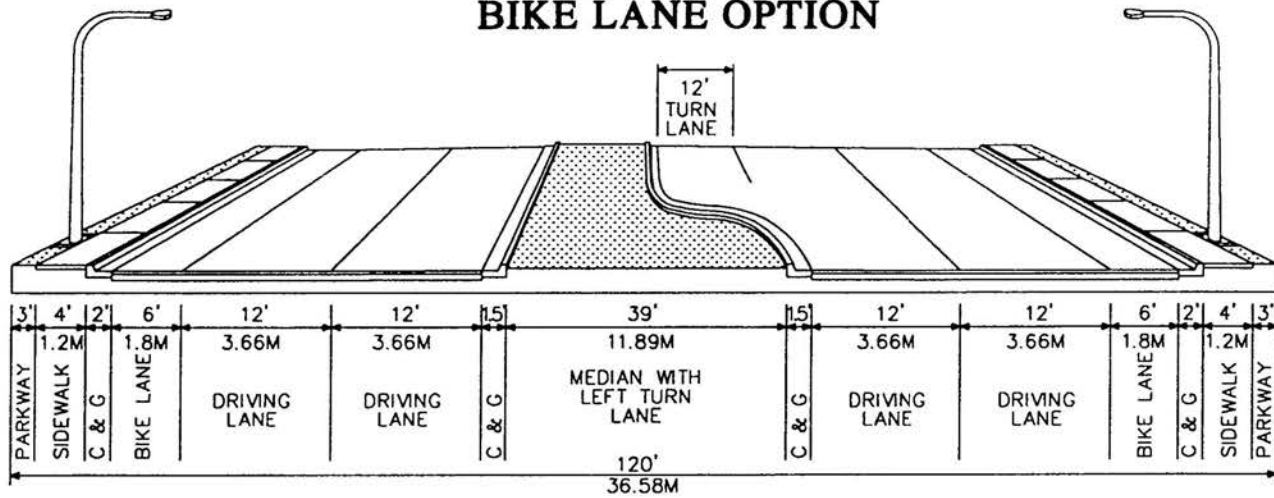

## MULTI-USE PATH OPTION

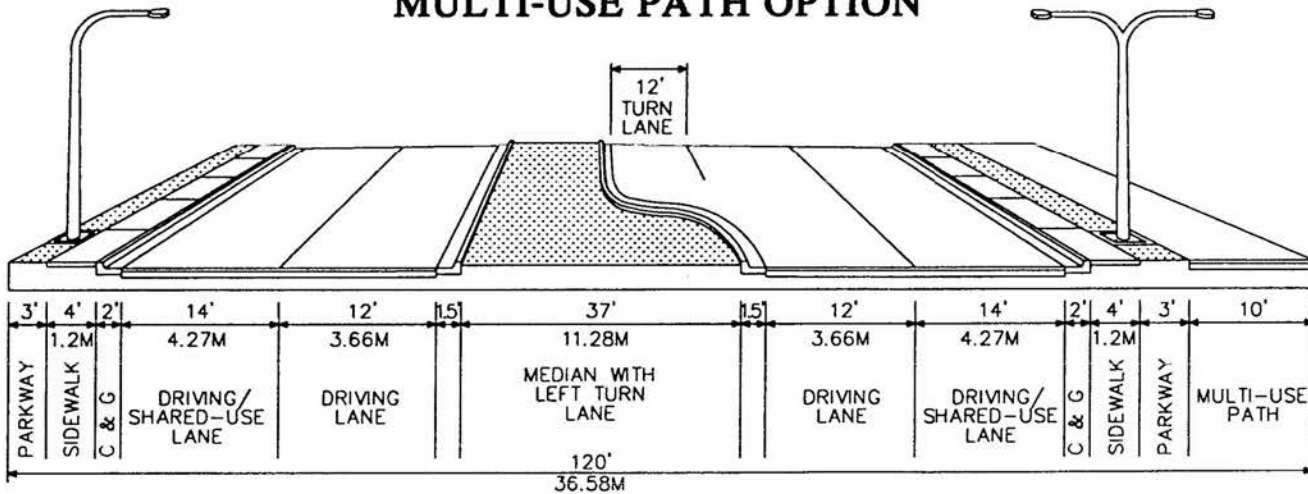

- NOTES:
1. THE DEVELOPER IS RESPONSIBLE FOR EXTENDING FULL SERVICE WATER STUBOUTS AND ELECTRICAL CONDUIT FOR LANDSCAPING IN EACH MEDIAN AND IN THE PARKWAYS.
  2. PARKWAY MAY BE USED BY THE ADJACENT LAND OWNER FOR LANDSCAPING. UP TO 1/3 OF THE REQUIRED LANDSCAPING MAY BE PLACED WITHIN THE RIGHT-OF-WAY.
  3. A MULTI-USE PATH OR BIKE LANE SHALL BE CONSTRUCTED WHEN REQUIRED BY THE BICYCLE FACILITIES & SYSTEMS MASTER PLAN.
  4. SIGNAGE AND PAVEMENT MARKINGS WILL BE REQUIRED IN ACCORDANCE WITH MUTCD.
  5. MEDIAN CURB & GUTTER, "TYPE K" OR "TYPE L", SHALL BE INSTALLED IN THE MEDIAN.
  6. MULTI-USE PATHS SHALL BE CONSTRUCTED ON THE NORTH SIDE OF EAST/WEST ROADS AND ON THE EAST SIDE OF NORTH/SOUTH ROADS.
  7. SIDEWALKS SHALL BE CONSTRUCTED ACCORDING TO SECTION 2.2 SIDEWALK REQUIREMENTS/OPTIONS.

(c) *Cul-de-sac requirements.* The use of cul-de-sacs in residential and commercial/industrial developments are permitted by these design standards;

- (1) A traditional bulb shaped cul-de-sac shall be considered the approved standard and its length shall be measured from the center line of the intersecting street to the center point of the cul-de-sac.
- (2) Hammerhead cul-de-sac length will be measured from the center line of the intersecting street to the back of curb at the end of the cul-de-sac.
- (3) *Cul-de-sac dimension requirements.*
  - a. Maximum cul-de-sac length will be 750 feet (228.6m) in residential or commercial subdivisions. An additional 750 foot (228.6m) of length which allows up to a 1500 feet (457.2m) cul-de-sac may be applied for through the development review committee when topography or land/lot configuration indicate the need for a longer cul-de-sac. A request for a cul-de-sac in excess of 750 feet (228.6m) shall be submitted to the subdivision administrator at the time of preliminary plat submittal. The subdivision administrator will process the request with the preliminary plat to the development review committee following the initial staff review. The development review committee will consider the request for additional length in light of peak hour traffic, number of units, size of lots, fire flow requirements, and any other considerations the development review committee may believe affects safety. Mitigation techniques such as, but not limited to, sprinkled fire suppression systems, additional hydrants, additional water lines to provide looped systems, increased street widths, and/or a secondary emergency vehicle access into the cul-de-sac at a remote point from the intersecting street may be required by the development review committee. In no case shall a waiver be granted to allow a cul-de-sac in excess of 1500 feet (457.2m).
  - b. The right-of-way and paving width of the stem of the cul-de-sac shall be the same width as the street classification given to the cul-de-sac. For example, if the cul-de-sac is serving a commercial development, it shall follow the requirements for a major local street.
  - c. A traditional bulb shaped cul-de-sac turnaround shall have a minimum radius of fifty (50) feet (15.24m). The minimum paving radius shall be thirty-six (36) feet (10.67m) including curbing.

- (4) *Alternative turn-around criteria.*
- a. Developments using hammerhead turnarounds shall be required to provide three off-street parking spaces per unit located along the turn-around as measured from the point of curvature to the point of curvature (PC/PC). The cul-de-sac shall be limited to a maximum length of 250 feet (76.2m) and a maximum of 16 single story dwelling units.
  - b. Cul-de-sacs with other alternative turnaround designs, i.e. offset bulb, tear-drop shaped, "Y" shaped, eyebrows, etc., shall be reviewed on a case by case basis by the development review committee.
- (5) In cases where on-street parking is not allowed in the cul-de-sac turnaround areas, signing of the cul-de-sac no parking areas shall be accomplished at the time of subdivision construction and in accordance with the manual on uniform traffic control devices for urban parking and stopping signs.

See next three pages for cul-de-sac details.

THIS SPACE INTENTIONALLY LEFT BLANK

RESIDENTIAL TURNAROUND CUL-DE-SAC

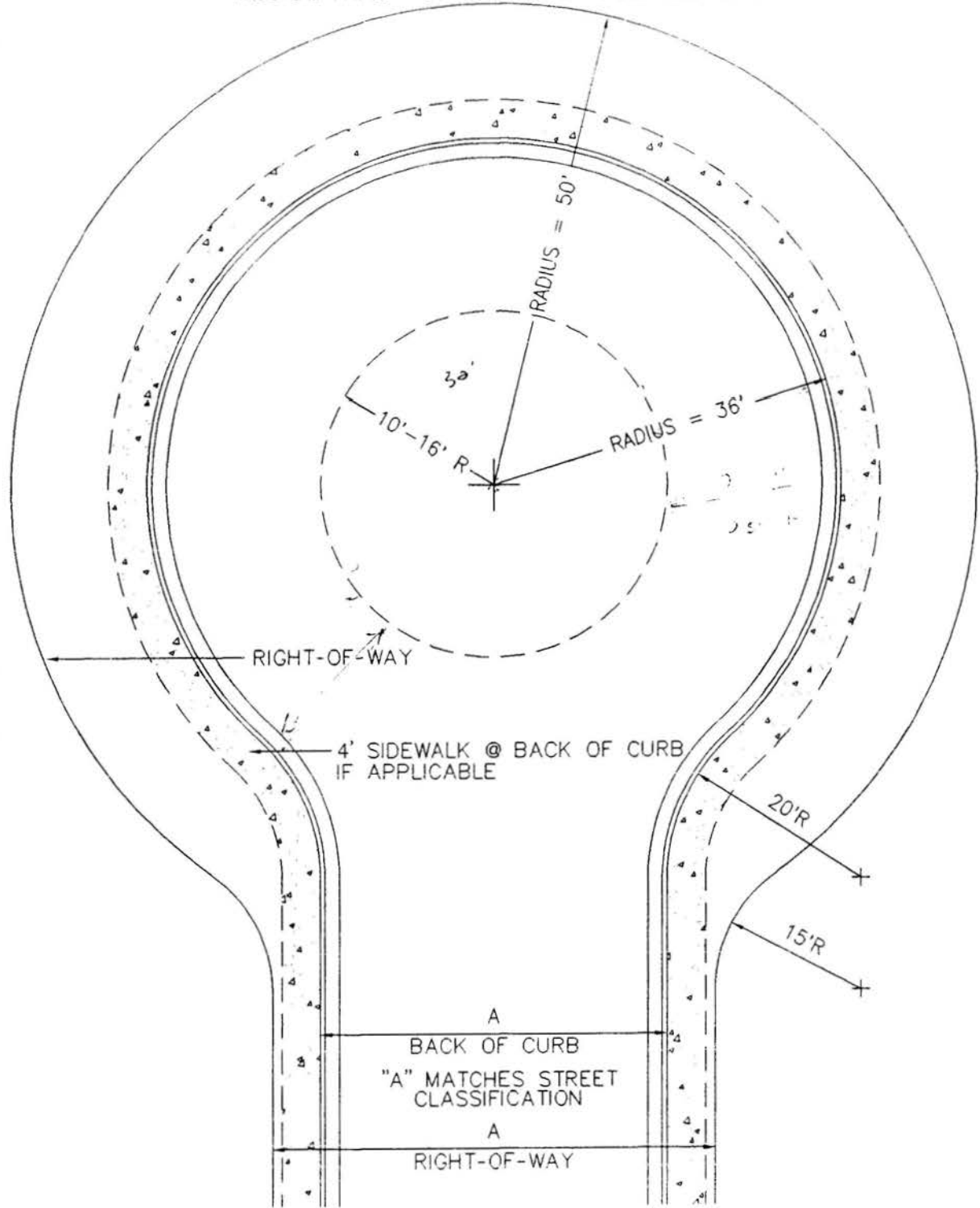

NOTES:

1. 36' BACK OF CURB RADIUS
2. OPTIONAL, CENTER LANDSCAPED MEDIAN - 10' MINIMUM, 16' MAXIMUM RADIUS - MOUNTABLE CURBING ONLY - MUST USE TYPE "G" OR "I".
3. NO PARKING ALLOWED ON CUL-DE-SAC.
4. SIGNING FOR NO ON STREET PARKING TO BE PROVIDED BY THE DEVELOPER PER MANUAL OF UNIFORM TRAFFIC CONTROL DEVICES.



RESIDENTIAL TURNAROUND CUL-DE-SAC

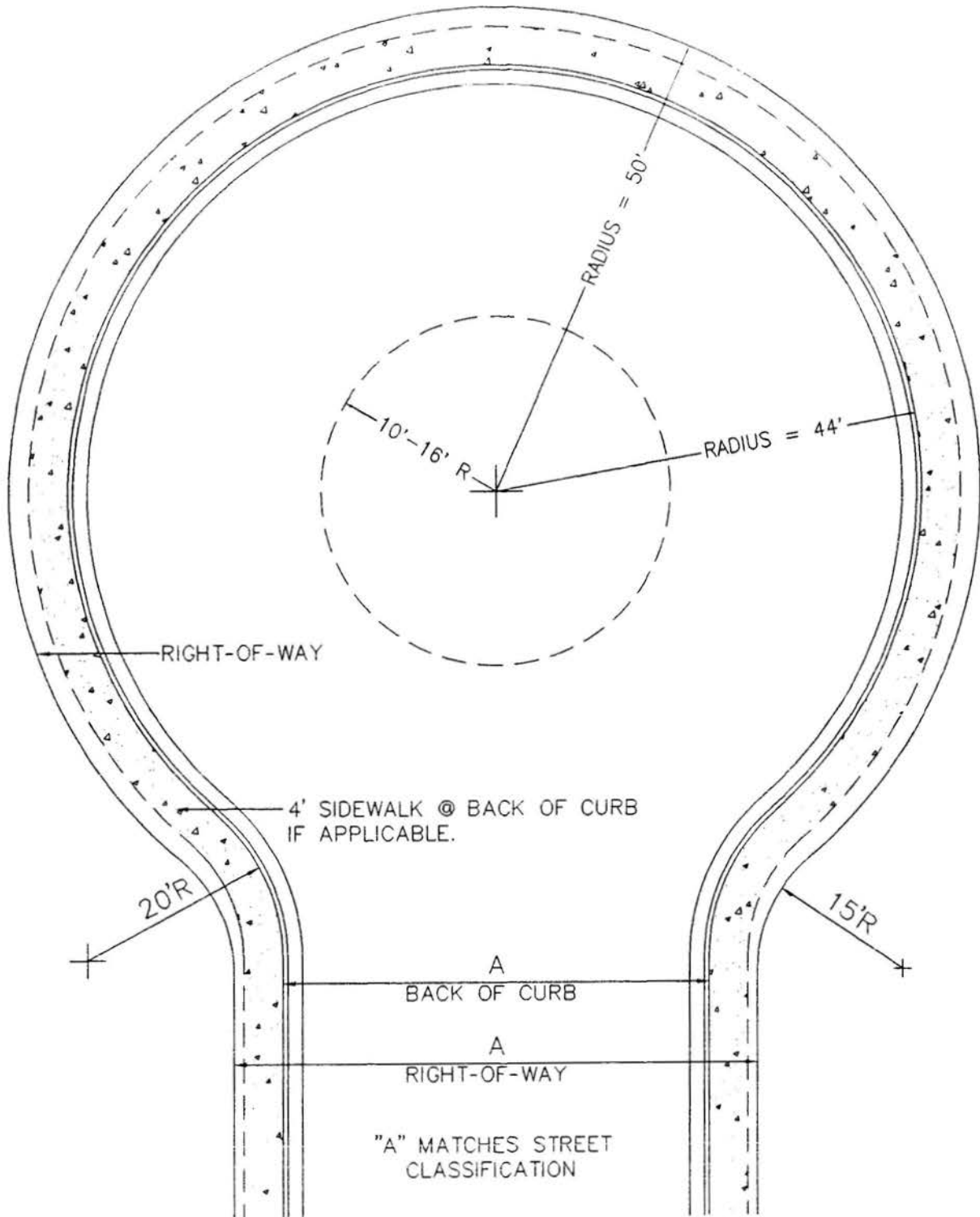

NOTES:

1. 36' BACK OF CURB RADIUS
2. OPTIONAL, CENTER LANDSCAPED MEDIAN - 10' MINIMUM, 16' MAXIMUM RADIUS - MOUNTABLE CURBING ONLY - MUST USE TYPE "G" OR "I".
3. PARKING ALLOWED ON CUL-DE-SAC.
4. SIGNING FOR NO ON STREET PARKING TO BE PROVIDED BY THE DEVELOPER PER MANUAL OF UNIFORM TRAFFIC CONTROL DEVICES.

# CITY OF LAS CRUCES

# DESIGN STANDARDS

## RESIDENTIAL HAMMERHEAD CUL-DE-SAC

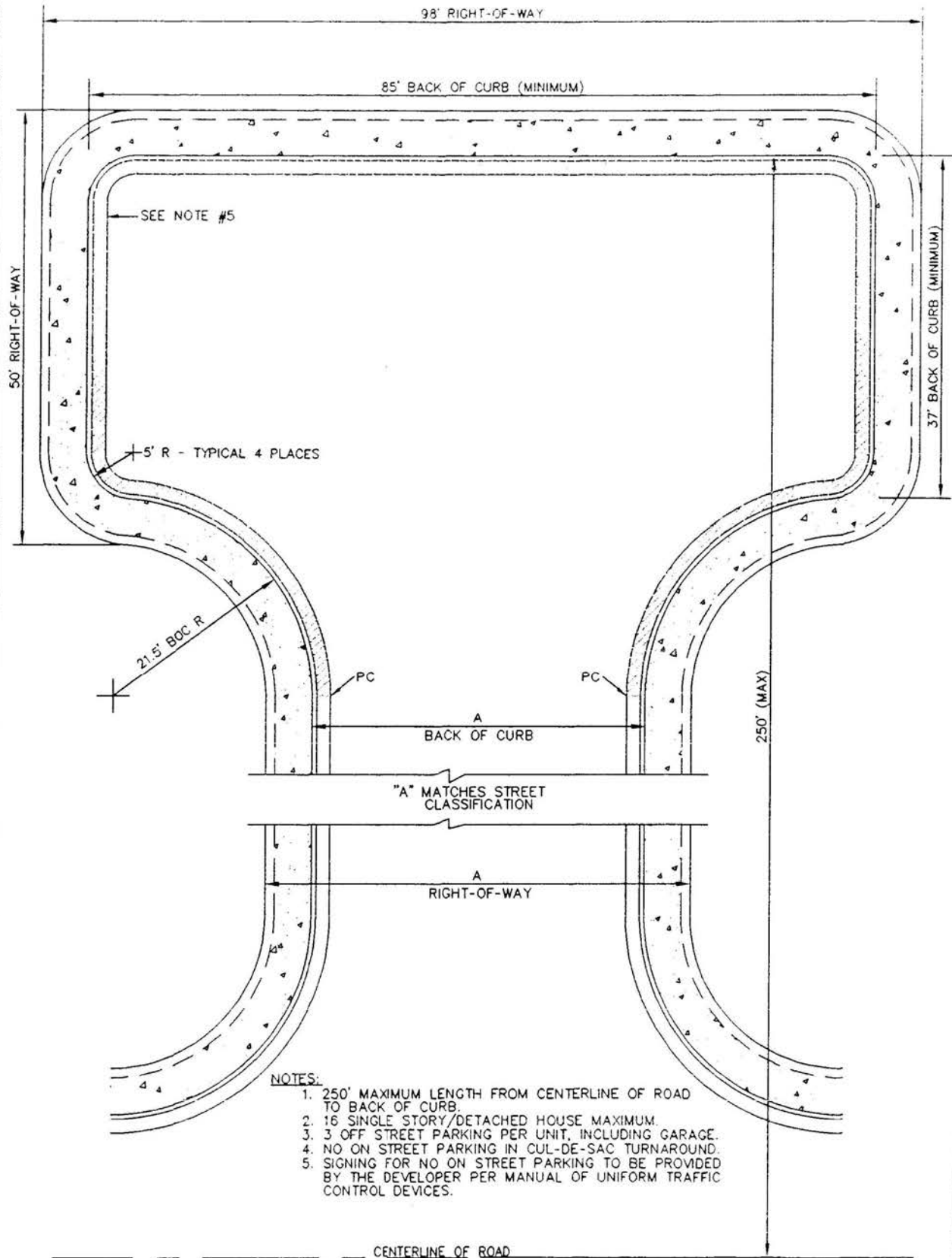

**NOTES:**

1. 250' MAXIMUM LENGTH FROM CENTERLINE OF ROAD TO BACK OF CURB.
2. 16 SINGLE STORY/DETACHED HOUSE MAXIMUM.
3. 3 OFF STREET PARKING PER UNIT, INCLUDING GARAGE.
4. NO ON STREET PARKING IN CUL-DE-SAC TURNAROUND.
5. SIGNING FOR NO ON STREET PARKING TO BE PROVIDED BY THE DEVELOPER PER MANUAL OF UNIFORM TRAFFIC CONTROL DEVICES.

(d) *Curbing.* All city streets require some form of approved curbing. Curb and gutter use is primarily dictated by drainage conveyance needs as well as traffic safety concerns. The following pages detail the approved curbing types as well as outline under what conditions the various curb types are applicable:

- (1) Type A, six-inch stand-up curb and gutter.
- (2) Type B, six-inch modified stand-up curb and gutter.
- (3) Type C, eight-inch stand-up curb and gutter.
- (4) Type D, eight-inch modified stand-up curb and gutter.
- (5) Type E, rollover curb and gutter.
- (6) Type F, modified rollover curb and gutter.
- (7) Type G, rollover curb and gutter.
- (8) Type H, drive over curb and gutter.
- (9) Type I, drive over curb and gutter.
- (10) Type J, header curb.
- (11) Type K, median curb and gutter.
- (12) Type L, modified median curb and gutter.
- (13) Type M, rundown gutter, four feet.
- (14) Type N, rundown gutter, two feet.
- (15) Type O, temporary asphalt curb.
- (16) Type P, temporary extruded concrete median curb.
- (17) Type Q, valley gutter.
- (18) Type R, drivepad curb.

See next 9 pages for curb details.

FOR USE ON ALL CITY STREET CLASSIFICATIONS AS A FUNCTION OF DRAINAGE AND TRAFFIC CONTROL.

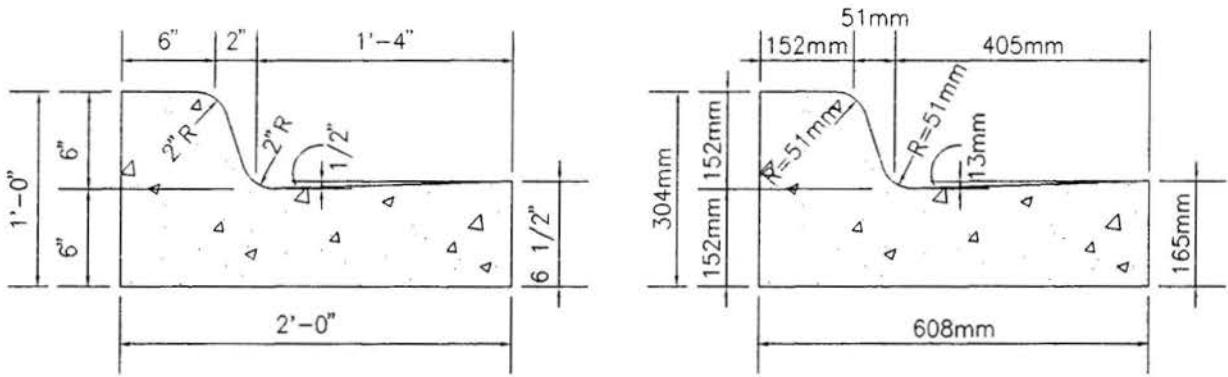

TYPE "A" CURB & GUTTER  
N.T.S.

FOR USE ON ALL CITY STREETS WHERE THE ROADWAY IS SUPERELEVATED. I.E. THE PAVEMENT SLOPES AWAY FROM THE CURB AND DRAINAGE IS TO BE DIVERTED FROM THE GUTTER SECTION.

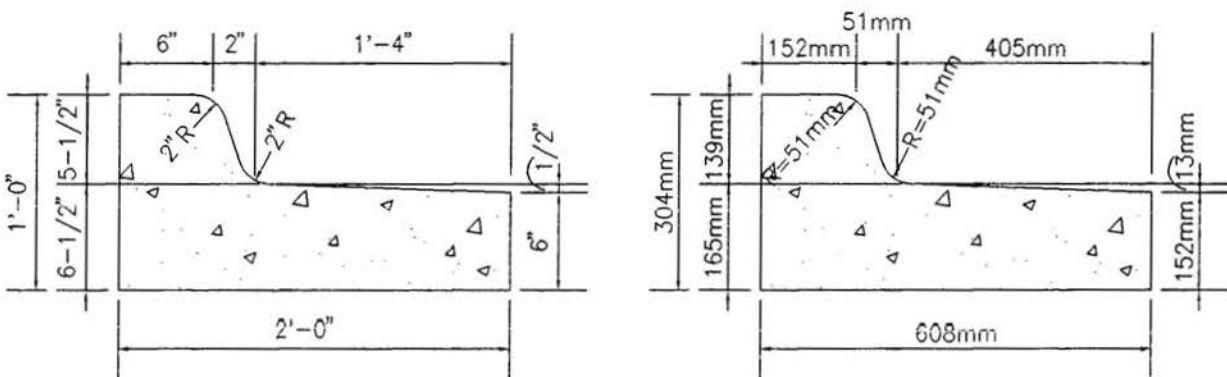

TYPE "B" MODIFIED CURB & GUTTER  
N.T.S.

# CITY OF LAS CRUCES

# DESIGN STANDARDS

FOR USE ON ALL CITY STREET CLASSIFICATIONS AS A FUNCTION OF DRAINAGE AND TRAFFIC CONTROL. IT IS PERMISSIBLE TO MIX CURB HEIGHTS OF 6" & 8" WHEN APPROPRIATE FOR PROPER DRAINAGE CONVEYANCE. MINIMUM TRANSITION LENGTH OF 10' FROM 6" TO 8" CURB. 8" CURB NOT RECOMMENDED FOR STREETS WITH ON-STREET PARKING.

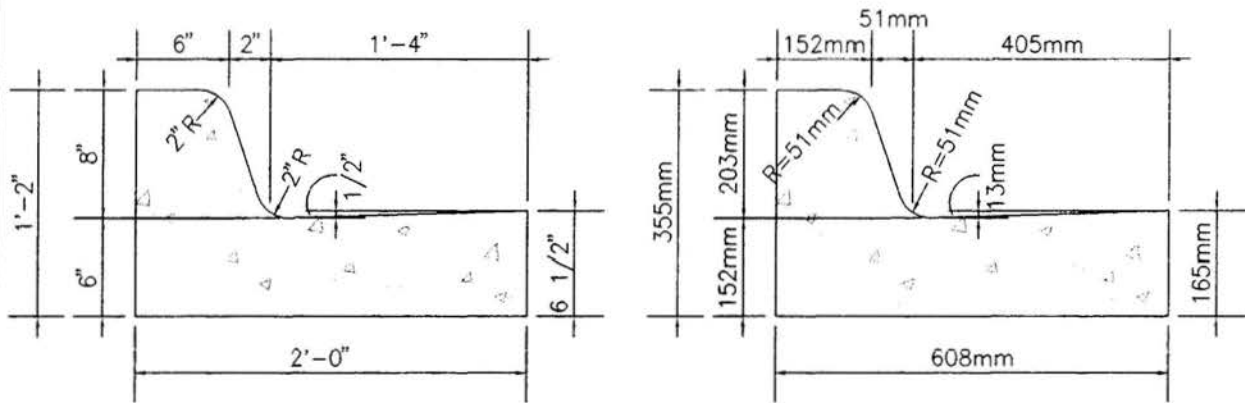

TYPE "C" 8" CURB & GUTTER  
N.T.S.

FOR USE ON CITY STREETS WHERE THE ROADWAY IS SUPERELEVATED, I.E. THE PAVEMENT SLOPES AWAY FROM THE CURB AND DRAINAGE IS TO BE DIVERTED.

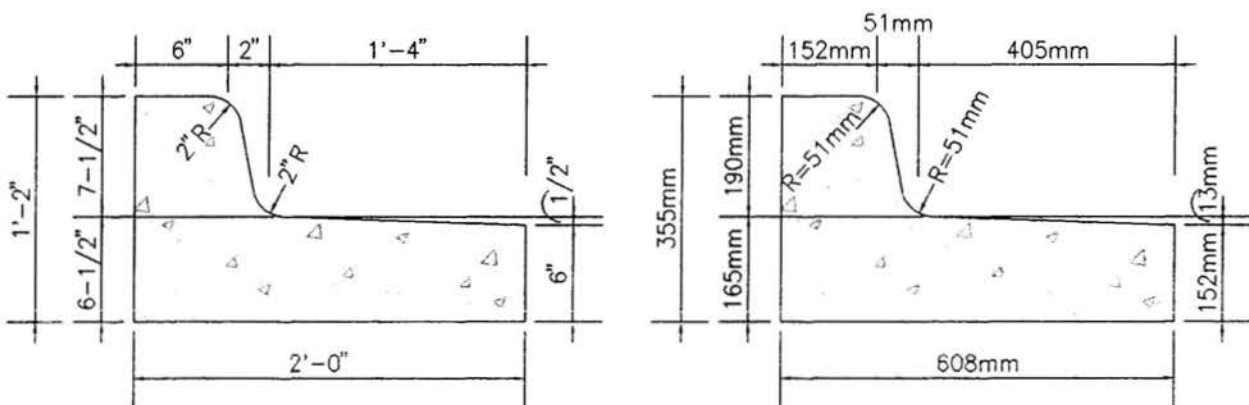

TYPE "D" 8" MODIFIED CURB & GUTTER  
N.T.S.

# CITY OF LAS CRUCES

# DESIGN STANDARDS

FOR USE ON MINOR LOCAL STREETS IN RESIDENTIAL DEVELOPMENTS HAVING ACCESS OF INDIVIDUAL DRIVEWAYS TO STREETS. ONCE USED, IT SHALL BE CONTINUED THROUGHOUT THE SUBDIVISION, TO INCLUDE EXTENDING TO THE NEXT STREET INTERSECTION. ALL CURB RETURNS SHALL BE A TYPE "A" OR "B" CURB AS REQUIRED FOR DRAINAGE WITH A MINIMUM 10' TRANSITION FROM THE PC & PT OF THE CURB RETURN TO THE TYPE "E" CURBING.

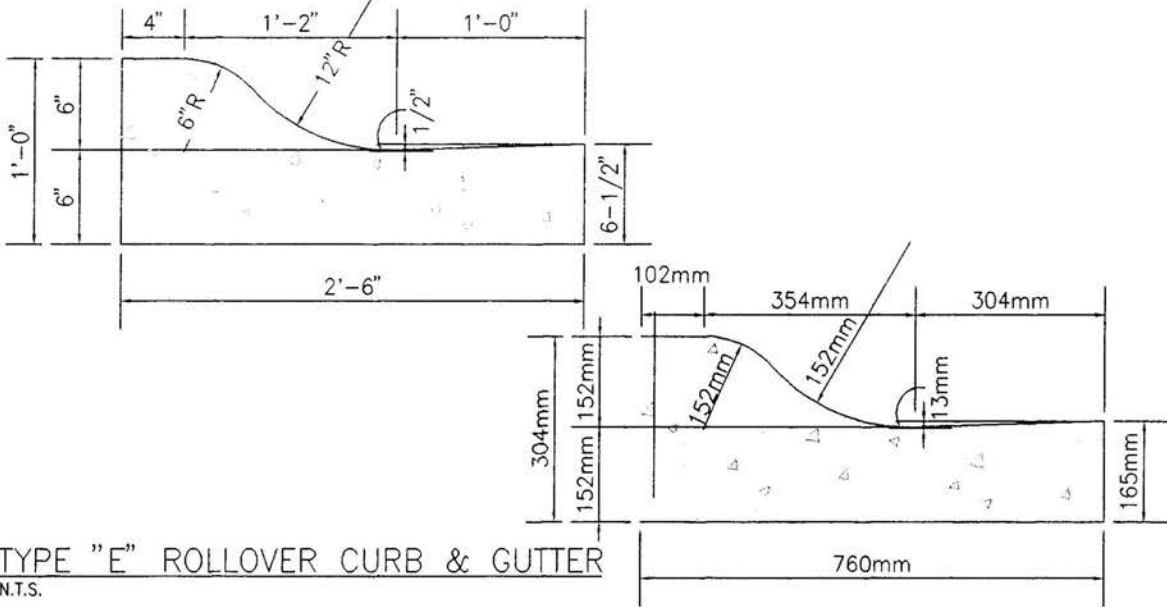

FOR USE ON MINOR LOCAL STREETS IN RESIDENTIAL DEVELOPMENTS HAVING ACCESS OF INDIVIDUAL DRIVEWAYS TO STREETS. ONCE USED, IT SHALL BE CONTINUED THROUGHOUT THE SUBDIVISION, TO INCLUDE EXTENDING TO THE NEXT STREET INTERSECTION. ALL CURB RETURNS SHALL BE A TYPE "A" OR "B" CURB AS REQUIRED FOR DRAINAGE WITH A MINIMUM 10' TRANSITION FROM THE PC & PT OF THE CURB RETURN TO THE TYPE "F" CURBING.

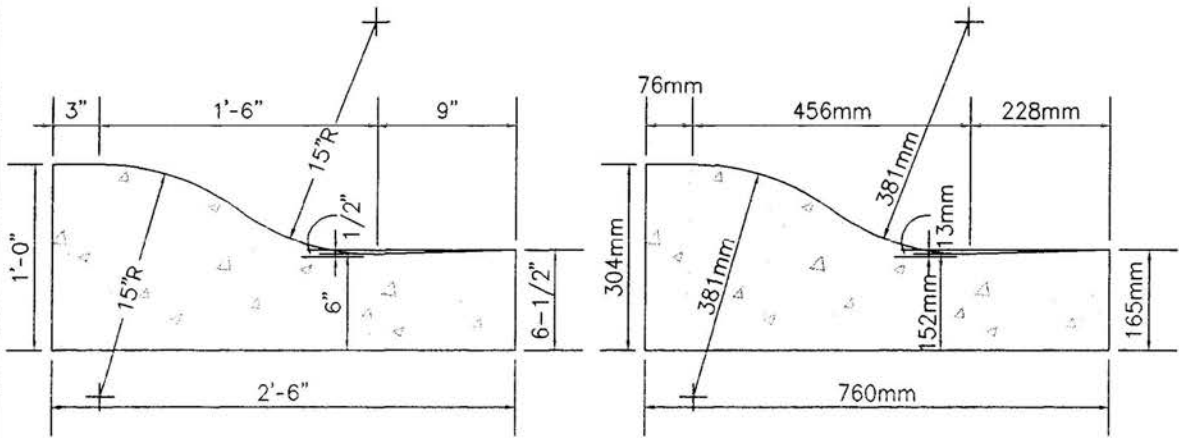



# CITY OF LAS CRUCES

# DESIGN STANDARDS

FOR USE ON MINOR LOCAL STREETS IN RESIDENTIAL DEVELOPMENTS HAVING ACCESS OF INDIVIDUAL DRIVEWAYS TO STREETS. ONCE USED, IT SHALL BE CONTINUED THROUGHOUT THE SUBDIVISION, TO INCLUDE EXTENDING TO THE NEXT STREET INTERSECTION. ALL CURB RETURNS SHALL BE A TYPE "A" OR "B" CURB AS REQUIRED FOR DRAINAGE WITH A MINIMUM 10' TRANSITION FROM THE PC & PT OF THE CURB RETURN TO THE TYPE "G" CURBING.

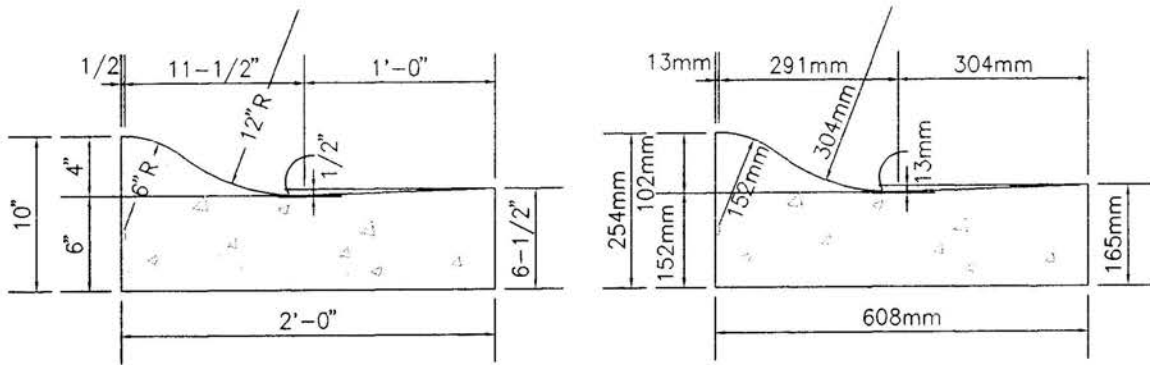

TYPE "G" ROLLOVER CURB & GUTTER  
N.T.S.

FOR USE ON MINOR LOCAL STREETS IN RESIDENTIAL DEVELOPMENTS HAVING ACCESS OF INDIVIDUAL DRIVEWAYS TO STREETS. ONCE USED, IT SHALL BE CONTINUED THROUGHOUT THE SUBDIVISION, TO INCLUDE EXTENDING TO THE NEXT STREET INTERSECTION. ALL CURB RETURNS SHALL BE A TYPE "A" OR "B" CURB AS REQUIRED FOR DRAINAGE WITH A MINIMUM 10' TRANSITION FROM THE PC & PT OF THE CURB RETURN TO THE TYPE "H" CURBING.

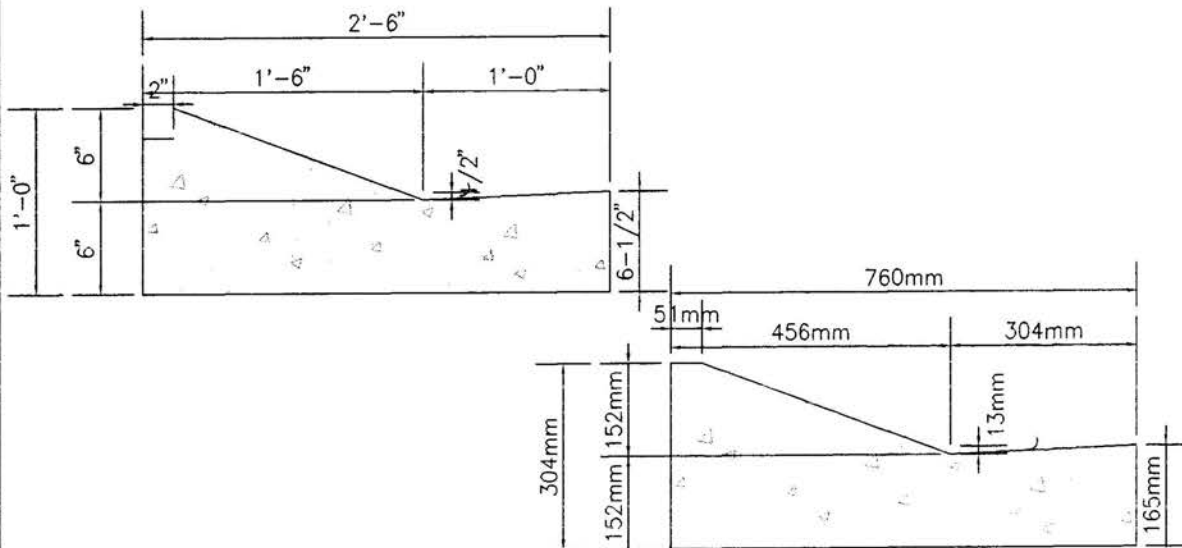

TYPE "H" DRIVE OVER CURB & GUTTER  
N.T.S.

CURB\_GH.DWG

MAY, 1997  
DRAWN BY: P. BASON

FOR USE ON MINOR LOCAL STREETS IN RESIDENTIAL DEVELOPMENTS HAVING ACCESS OF INDIVIDUAL DRIVEWAYS TO STREETS. ONCE USED, IT SHALL BE CONTINUED THROUGHOUT THE SUBDIVISION, TO INCLUDE EXTENDING TO THE NEXT STREET INTERSECTION. ALL CURB RETURNS SHALL BE A TYPE "A" OR "B" CURB AS REQUIRED FOR DRAINAGE WITH A MINIMUM 10' TRANSITION FROM THE PC & PT OF THE CURB RETURN TO THE TYPE "I" CURBING.

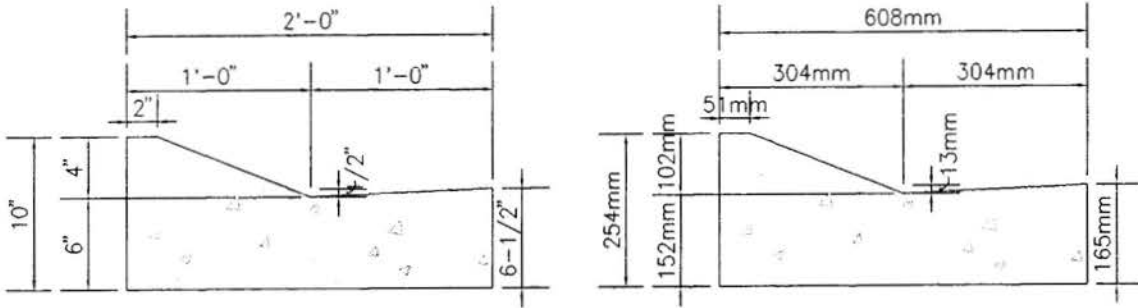

TYPE "I" DRIVE OVER CURB & GUTTER  
N.T.S.

TO BE USED TO MAINTAIN THE STREET EDGE AND WHEN SIDEWALKS ARE NOT REQUIRED. FOR USE ON THE VALLEY FLOOR TO CONVEY DRAINAGE OFF THE STREET.

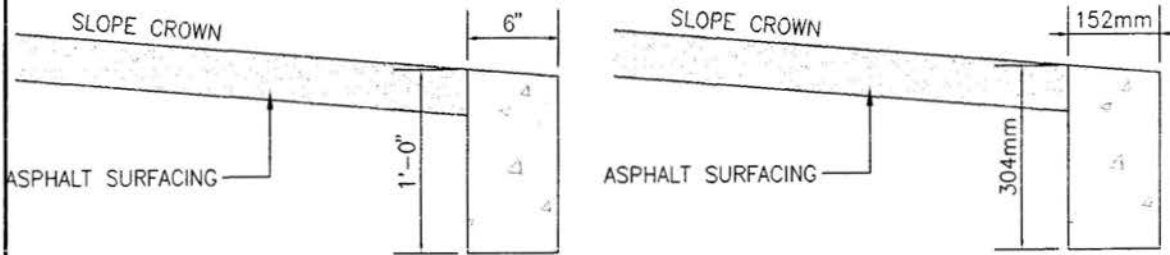

TYPE "J" HEADER CURB  
N.T.S.

# CITY OF LAS CRUCES

# DESIGN STANDARDS

FOR USE ON CENTER LANE MEDIANS ON COLLECTOR OR ARTERIAL STREET SECTIONS TO CONVEY DRAINAGE. THE SLOPE OF THE GUTTER SHALL BE REQUIRED TO MATCH THE SLOPE OF THE STREET. 8" CURBING MAY BE REQUIRED AS DICTATED BY DRAINAGE NEEDS.

\* CURB HEIGHT = 8", TOTAL CURB THICKNESS = 14"

\* CURB HEIGHT = 203mm, TOTAL CURB THICKNESS = 355mm

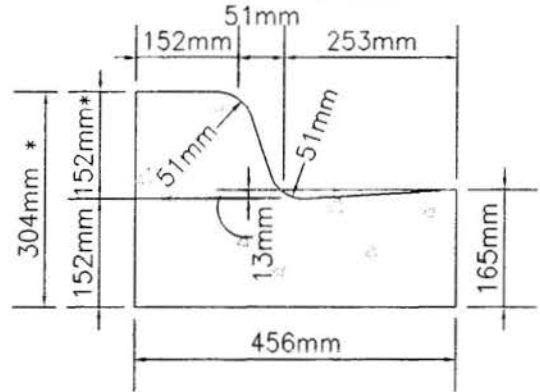
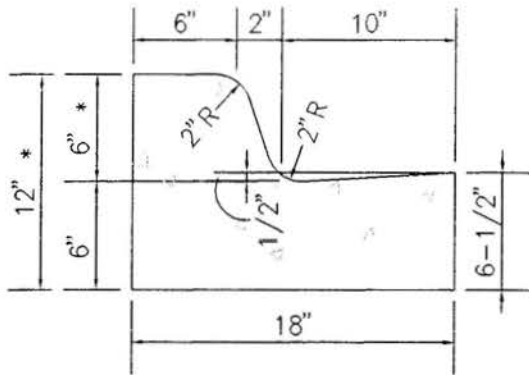

TYPE "K" MEDIAN CURB & GUTTER  
N.T.S.

FOR USE ON CENTER LANE MEDIANS ON COLLECTOR OR ARTERIAL STREET SECTIONS TO CONVEY DRAINAGE. THE SLOPE OF THE GUTTER SHALL BE REQUIRED TO MATCH THE SLOPE OF THE STREET. TO BE USED ON SUPERELEVATED MEDIANS. 8" CURBING MAY BE REQUIRED AS DICTATED BY DRAINAGE NEEDS.

\* CURB HEIGHT = 7-1/2", TOTAL CURB THICKNESS = 14"

\* CURB HEIGHT = 190mm, TOTAL CURB THICKNESS = 355mm

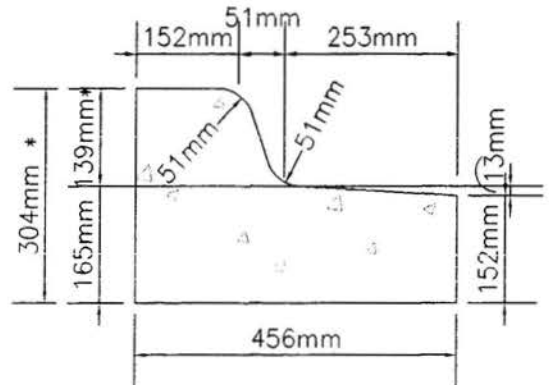
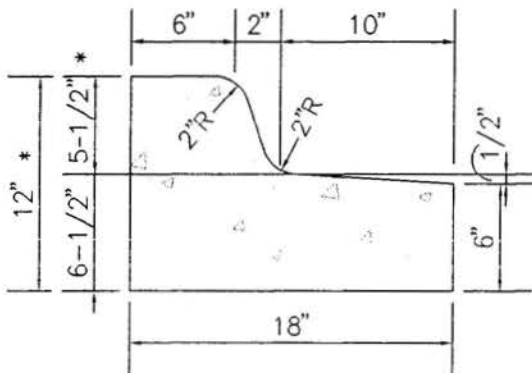

TYPE "L" MODIFIED MEDIAN CURB & GUTTER  
N.T.S.

FOR USE IN RELATIVELY FLAT AREAS IN CONJUNCTION WITH STORMWATER DRAINAGE FACILITIES ONLY. THIS SECTION IS INTENDED TO TAKE THE PLACE OF SIDEWALKS IN LOCATIONS WHERE SIDEWALKS WOULD BE REQUIRED.

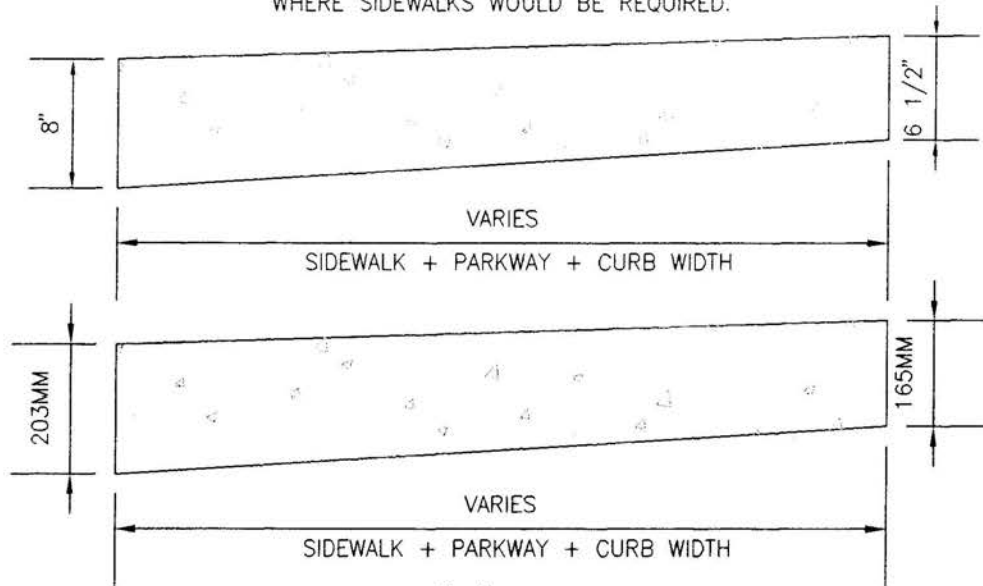

TYPE "M" RUNDOWN  
N.T.S.

FOR USE IN RELATIVELY FLAT AREAS IN CONJUNCTION WITH STORMWATER DRAINAGE FACILITIES ONLY. THIS SECTION IS NOT INTENDED TO TAKE THE PLACE OF SIDEWALKS IN LOCATIONS WHERE SIDEWALKS WOULD BE REQUIRED.

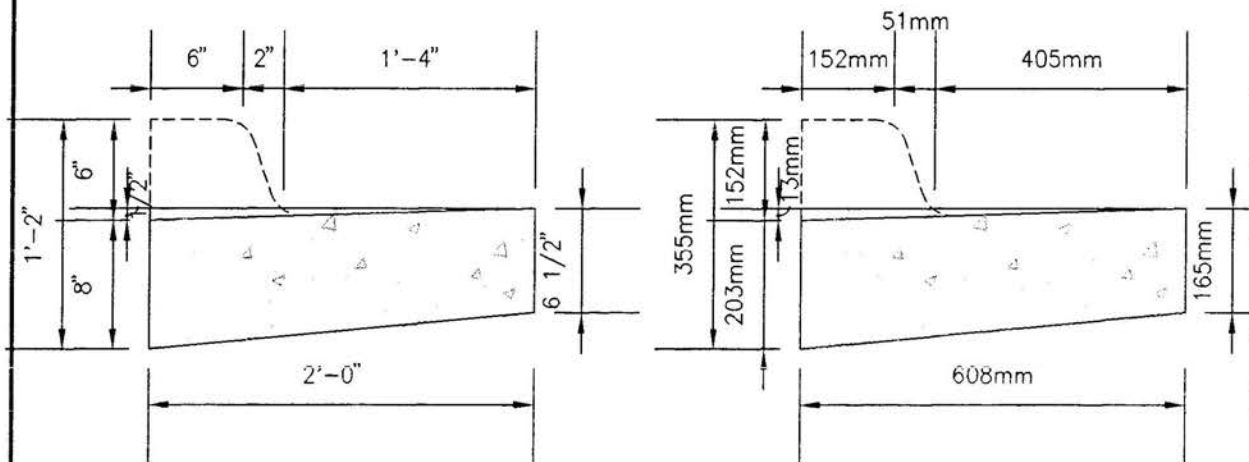

TYPE "N" RUNDOWN  
N.T.S.

FOR USE ON STREETS WHERE THE ESTIMATED EXPANSION OF THE ROAD IS TO OCCUR WITHIN THE NEXT TEN (10) YEARS.

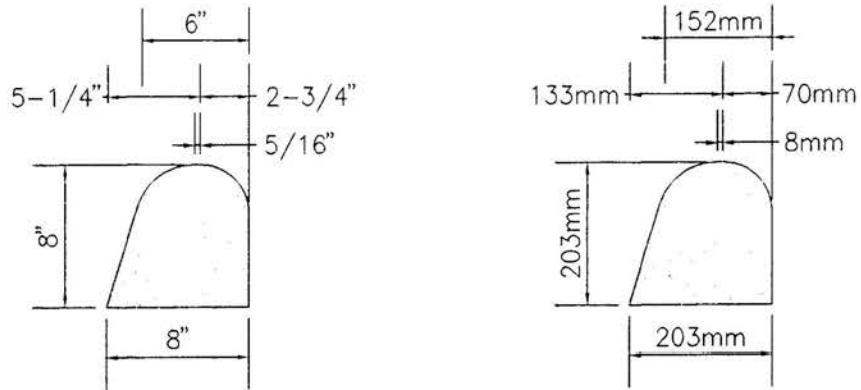

TYPE "O" TEMPORARY ASPHALT CURB  
N.T.S.

FOR USE ON STREETS WHEN EXPANSION TO THE CENTER IS PLANNED IN EXCESS OF TEN (10) YEARS. NO DRAINAGE IS TO BE CONVEYED IN OR ON THE MEDIAN. CURB IS TO BE REMOVED.

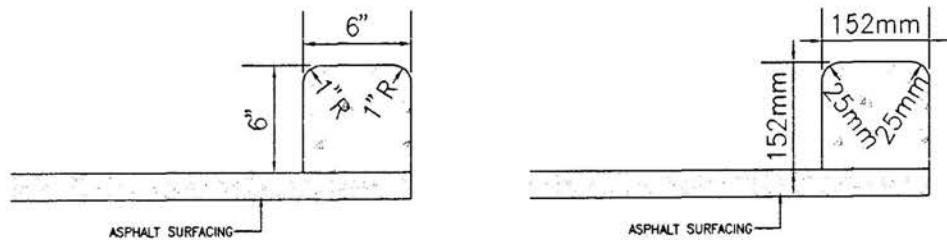

TYPE "P" TEMPORARY EXTRUDED CONCRETE MEDIAN CURB  
N.T.S.

# CITY OF LAS CRUCES

# DESIGN STANDARDS

FOR USE WHERE NECESSARY ON EXTREMELY FLAT GRADES FOR DRAINAGE CONVEYANCE. SLOPE OF GUTTER TO MATCH STREET GUTTER SECTION. IN NO INSTANCE WILL THE SLOPE BE LESS THAN 2% (1/4"/FT). VALLEY GUTTERS WILL BE REQUIRED AT ALL STREET INTERSECTIONS WHERE SLOPE OF INTERSECTION IS 0.7% OR LESS.

**NOTE:**

AN INVERTED CROWN STREET CAN BE APPROVED THROUGH ERC. IF APPROVED BY ERC A VALLEY GUTTER WILL BE REQUIRED IN THAT STREET SECTION.

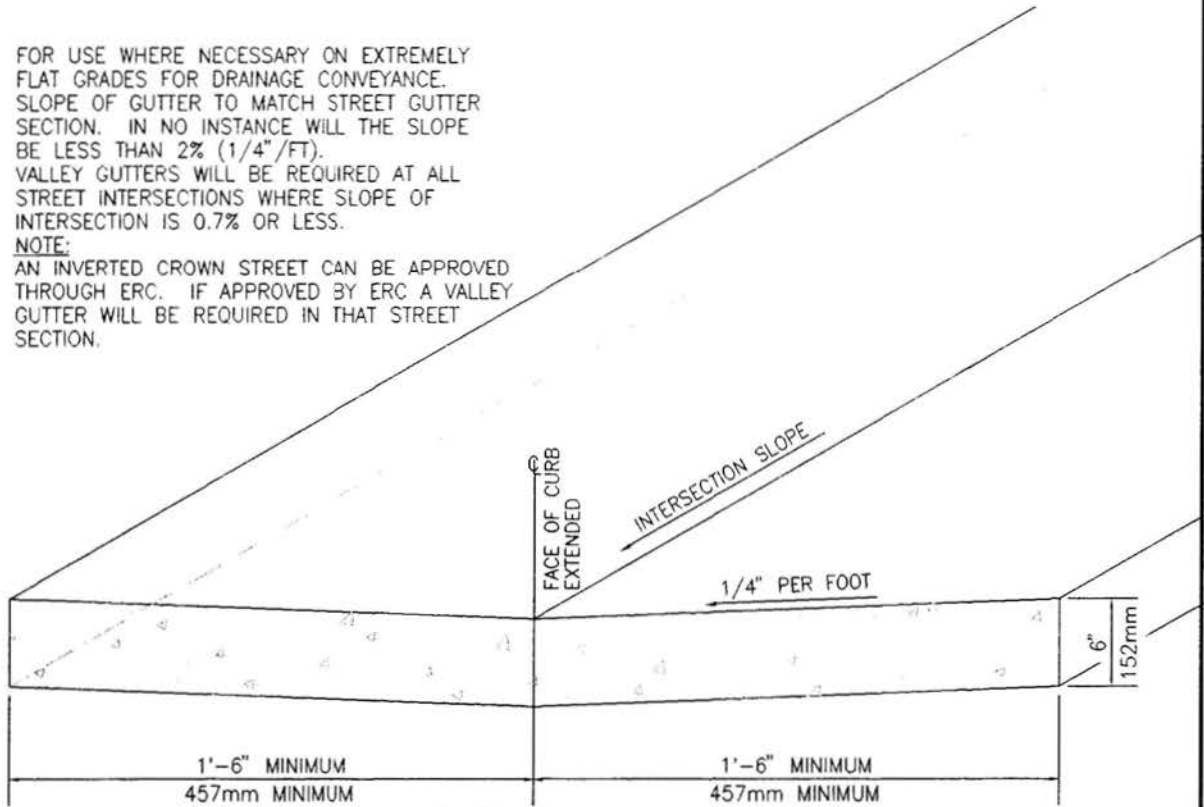

**TYPE "Q" VALLEY GUTTER**  
N.T.S.

FOR USE ON ALL DRIVEPADS, EXCEPT WHERE ROLLOVER OR MOUNTABLE CURBING IS INSTALLED.

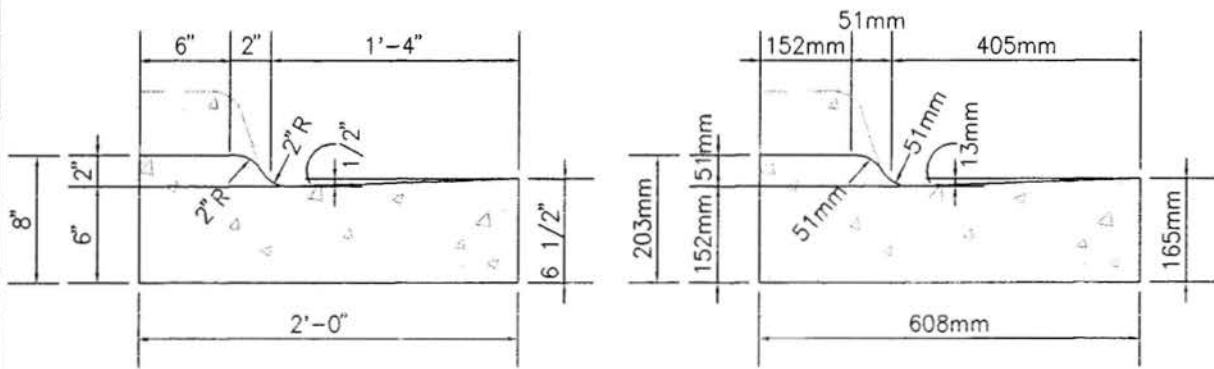

**TYPE "R" DRIVEPAD CURB**  
N.T.S.

(e) *General design criteria for streets.*

- (1) Minimum right-of-way radius at intersections:
  - a. Rights-of-way 15 feet (4.57m) at property line for minor local roads.
  - b. Rights-of-way 25 feet (7.62m) at property line for all classifications higher than minor local.
- (2) Minimum side slope outside right-of-way (steepest slope), two (horizontal) to one (vertical).
- (3) Street logs with centerline offsets of less than 125 feet (38. 10m) shall not be permitted on local streets. Street jogs shall not be permitted for collectors or arterials.
- (4) Streets shall be laid out so as to intersect as nearly as possible at right angles, and no street shall intersect any collector or arterial street at less than 75 degrees and no local or light commercial streets at less than 60 degrees.

TABLE I

STANDARD UNITS  
GENERAL DESIGN CRITERIA FOR STREETS  
(NUMBERS IN PARENTHESES APPLY TO FOOTNOTES)

Street Classification	Minimum Centerline Radius (Feet)(10)				Vertical Curve Requirement(4), (7) Vertical Curvature Design Value(2)			
	Design Speed mph	0.02 Feet/Feet Super-elevation (feet)	With Normal Crown(6), (8) (feet)	Min. Length Vertical Curve (feet)(1)	K Value For Crest Stopping Sight Distance(5)	K Value For SAG Stopping Sight Distance(5)	Change Allowed Without Vertical Curve (percentage)(7)	Maximum Grade Allowed (percentage)(9)
Major arterial	50	1,050	1,400	150	160	110	0.4	7
Minor arterial	45	800	1,100	135	120	90	0.4	7
Collector	35	450	600	100	50	50	0.7	8
Major Local	30	380	380	50	30	40	1.0	10
Minor Local	25	180	* 180	50	20	30	1.0	10
Low Density Local	15	180	* 180	50	20	30	1.0	10



METRIC UNITS  
GENERAL DESIGN CRITERIA FOR STREETS  
(NUMBERS IN PARENTHESES APPLY TO FOOTNOTES)

Street Classification	Minimum Centerline Radius (Feet)(10)				Vertical Curve Requirement(4),(7) Vertical Curvature Design Value(2)			
	Design Speed (km/h)	0.02 m/m Super-elevation (m)	With Normal Crown (m)(6), (8)	Min. Length Vertical Curve (m)(1)	K Value For Crest Stopping Sight Distance(5)	K Value For SAG Stopping Sight Distance(5)	Change Allowed Without Vertical Curve (percentage)(7)	Maximum Grade Allowed (percentage)(9)
Major arterial	80	320	425	50	160	110	0.4	7
Minor arterial	70	245	335	40	120	90	0.4	7
Collector	55	135	185	30	50	50	0.7	8
Major Local	45	115	115	15	30	40	1.0	10
Minor Local	40	70	55	15	20	30	1.0	10
Low Density Local	25	70	55	15	20	30	1.0	10

Major local, minor local, and low density local street intersections(10)

Major arterial, minor arterial and collector street intersections with or without traffic signals(11)

\* Cul-de-Sacs R=120 feet

Footnotes for table 1

1. Controlling limit only when algebraic grade difference A times the design value K is less than minimum shown: in all other cases,  $L = KA$  shall control.
2. The values for K shown are to be used in determining the minimum length of vertical curve required by the use of the relationship  $L = KA$ .

Where:

$L$  = Length of vertical curve in feet

$A$  = Algebraic difference in grades expressed in percent

$K$  = Design value indicate of rate of curvature

3. Lengths of vertical curves longer than the minimums resulting from the use of K values shown should be used wherever possible; however, K

should not exceed 167 feet (50.90m) per percent change in grade when curb and gutter is used for drainage considerations.

4. Crest vertical curves are based on eye height of three feet, three inches, object height of six inches and AASHTO minimum stopping distances. SAG vertical curves are based on AASHTO standards. If AASHTO standards are revised to more restrictive values, the more restrictive values shall supersede the values of this table.
5. The crown will be a minimum of one-half percent and maximum 2 1/2 percent. Streets with cross slope shall not exceed five percent. Greater cross slopes may be allowed only with the express written permission of the public works director or at street intersections. Calculations shall be submitted for review and approval for cross slopes greater than five percent indicating the conveyance capacity of the street section for drainage runoff.
6. A minimum of 50 feet (15.24m) distance equal to the minimum length vertical curve must be maintained between vertical points of intersection.
7. Local residential streets with 90-degree or near 90-degree (interior angle between 80 degrees and 110 degrees) turns may be designed with a minimum centerline radius of 50 feet (15.24m) with the express written permission of the public works director. Appropriate advisory signs may be required.
8. Minimum slope in streets with standard curb and gutter shall be one-half percent. Minimum slope in streets with header curb or rundown curb shall be zero percent. The crown on a zero-percent to one-half percent street shall be a minimum two percent.
9. Major local, minor local and low density local street intersections shall have a maximum algebraic difference in grades expressed in percent of five (street slope minus crown slope). All nonthrough streets shall have a minimum 25 feet (7.62m) landing from the flowline of the intersecting street with vertical curves, meeting the criteria listed in table I for the different street classifications, beginning at the end of the landing. All through streets shall meet the criteria listed In Table I for the different street classifications for vertical curves. See drawings below.
10. Major arterial, minor arterial and collector street intersections with or without traffic signals shall meet the criteria listed in Table I for the different street classifications for vertical curves. Design of vertical curves within the street Intersection shall accommodate all drainage conveyance runoff.

11. Source: Design of Urban Streets, Federal Highway Administration; U.S. Department of Transportation.

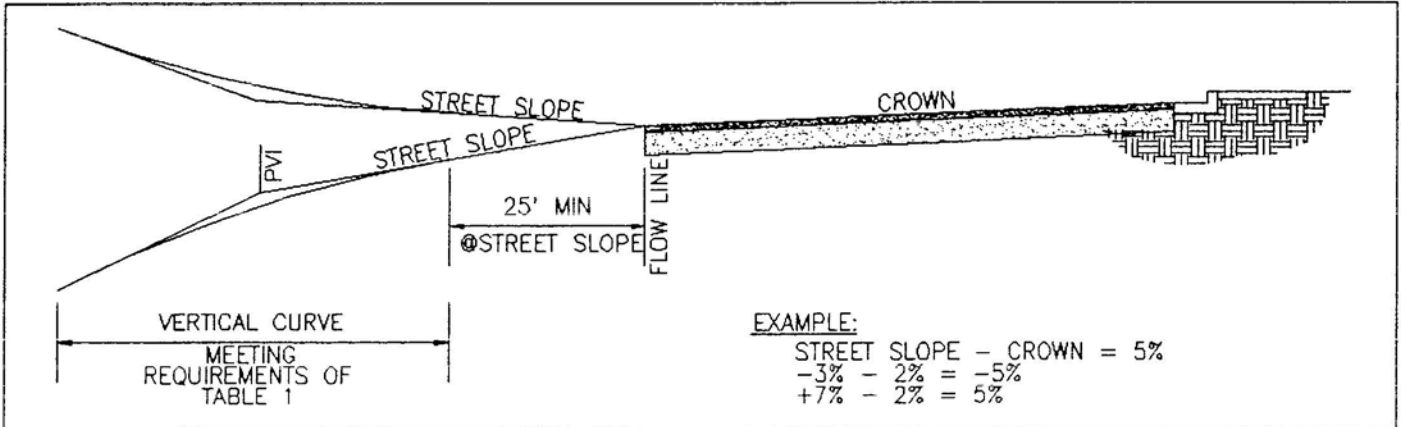
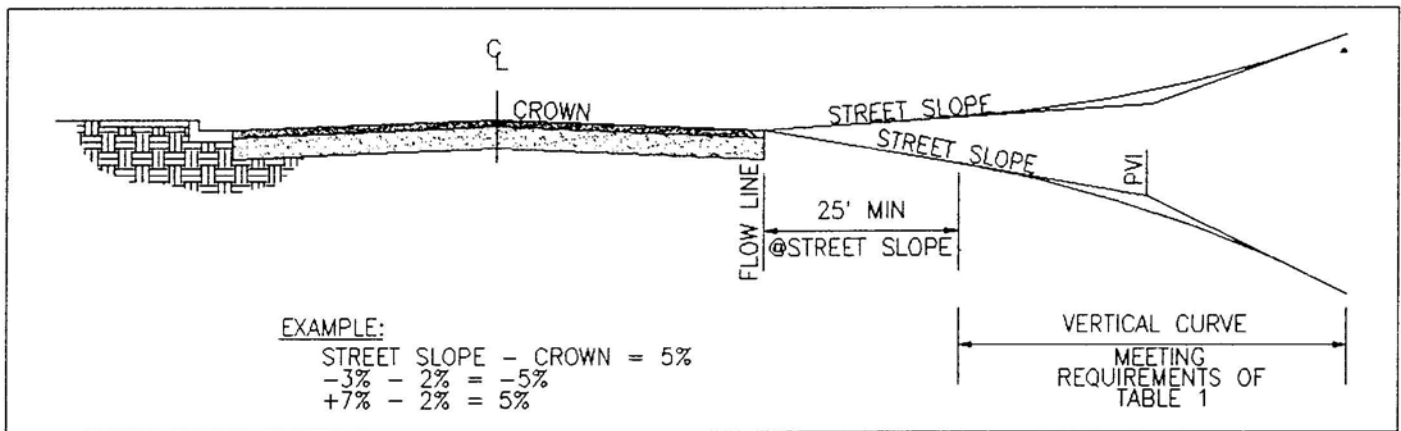

**Sec. 32-37. Sidewalk requirements.**

Sidewalks for pedestrian traffic are required when a street is built in the city. The only exception to this requirement shall be a low density local street with stand-up curb and gutter. Sidewalks shall be required along all streets where the average residential lot size of adjacent lots is one-half acres (2023.44m<sup>2</sup>) and less.

(1) When this requirement is applied. It shall be the responsibility of the developer, at the time of subdivision construction, to prepare all sidewalk subgrade and to construct the sidewalks along all collector and arterial streets or any other street classified higher than a minor local. The construction of sidewalks along all local streets shall be the responsibility of the building contractor or the homeowner If they are not provided by the developer. The sidewalk may have a minimum thickness of four inches (101.6mm) if the sidewalk is built at the time of roadway construction and the subgrade and base course under the sidewalk is the same as under the roadway and if the sidewalk -is built flush with the street without curb and gutter, or if a mountable type curb is used. A minimum thickness of six inches (152.4mm) is required if the sidewalk is not constructed

at the time of roadway construction and is abutting a mountable type curb. Sidewalks shall be built in accordance with current concrete specifications as per the City of Las Cruces Standard Specifications for Road Construction, as amended.

(2) Standards for sidewalk construction.

- a. Sidewalks shall be adjacent to curb or pavement. When a sidewalk is built flush with the street, utilizing a mountable type curb, then the sidewalk shall have a minimum thickness of four inches (101.6mm) if constructed at the same time as roadway construction or six inches (152.4mm) if not built at the time of the roadway. The four-inch (101.6mm) sidewalk when adjacent to mountable type curbing shall be designed as a rigid pavement (concrete) based on twenty of the street average daily load (ADL). Sidewalk in lieu of curb and gutter shall be designed as a rigid pavement (concrete) using street ADL. A minimum thickness of six inches (152.4mm) is required if the sidewalk is not constructed at the same time as roadway construction or if the sidewalk abuts the pavement.
- b. Wheelchair ramps with sidewalk from point of curve (PC) to point of tangency (PT) shall be constructed in accordance with applicable sections of the Americans With Disabilities Act (ADA) at the time of roadway construction.
- c. Sidewalks shall have a minimum width of four unobstructed feet (1.22m). Street lights, power poles, fire hydrants, street signs or other types of obstructions shall not be permitted in the sidewalks. If street obstructions are in the way of proposed sidewalks, the obstructions shall be relocated prior to construction of the sidewalk or the sidewalk shall be widened to allow four feet (1.22m) of unobstructed width.
- d. The material under the sidewalk shall be a minimum of six inches (152.4mm) of A-2-4 material (pursuant to AASHTO Soil Classification) with a minimum compaction of 95 percent.

(Ord. No. 949, § 2.2, 9-8-87; Ord. No. 1745, § I, 6-7-99)

**Sec. 32-38. Street lights--Specifications for installation.**

(a) *Conduit.* Conduit shall be one and one-half inch (38.10mm) PVC Type, Schedule 40. Installation depth shall be 18 inches (457.20mm) minimum and 24 inches (609.60mm) maximum. Variation from these depths, when crossing other utilities to maintain twelve inches (604.80mm) separation, is allowable when approved by the public works director or his/her designee. Location and alignment shall be as shown on standard construction drawing, unless otherwise specified on the subdivision construction plans.

(b) *Backfill.* Backfill shall be as stated in the city standard specifications for road construction, as amended.

(c) *Foundations for street lights.*

**STREET LIGHT FOUNDATION REQUIREMENTS**

Street Light Pole Height	Foundation Size Specifications
25' (7.62m) pole with 6' (1.83m) arm	2' × 2' × 3' (0.61m × 0.61m × 0.91m)
35'(10.66m) pole with 8' (2.43m) arm	3' × 3' × 4' (0.91m × 0.91m × 1.22m)
Dual arm pole	3' × 3' × 5' (0.91m × 0.91m × 1.52m)

All poles shall require bolts with nuts and washers (furnished by the city with bolt template); a ground rod five-eighths of an inch × eight feet (15.88mm × 2.44m); one-half inch (12.70mm) rebar reinforcement, approximately forty linear feet (12.19m), as shown on construction plans; one and one-half inch (38.10mm) PVC conduit for continuous circuit; and, Class A 3,000 PSI (20,684.27kPa) concrete. Material test of concrete shall be made, when specified by the public works director or his/her designee.

d. *Joint use of underground trench.* Joint use of trench for the installation of electrical service by El Paso electric company, and/or for street light circuits, is acceptable when approved by both the city and El Paso electric company.

e. *Completion of street light system.* When development of housing begins, and subject to notification given to the city public works department by the contractor/developer, the city shall complete the installation of the street light system to full operation.

(Ord. No. 949, § 2.3, 9-8-87; Ord. No. 1224, § 1, 3-18-91; Ord. No. 1745, § I, 6-7-99; Ord. No. 1929, §§ I, II, 8-5-02)

**Note:** For further information, refer to the street lighting policy and ground rules for installation of street lighting.

**Sec. 32-39. Utility improvements.**

(a) *General.*

(1) Subdivider shall be responsible for all design and construction costs.

(2) All water, sewer, and gas construction shall meet or exceed utilities department and Rio Grande natural gas association standard specifications for construction of water, sewer, and gas utilities, hereinafter called "city specifications" as adopted by the city council from time to time.

- (3) City specifications shall apply to all water, sewer, and gas construction in subdivisions within the planning and platting jurisdiction of the city, to include required fire flows.

(b) *Water and sewer.* When a community water and/or sewer system is to be constructed, the subdivider shall include deed restrictions on the final plat requiring that any individual water supply system or wastewater treatment system comply with requirements of the NMED.

(c) *Gas.* If the subdivider desires to install a natural gas system within the subdivision, the system must meet or exceed city specifications.  
(Ord. No. 949, § 2.4, 9-8-87; Ord. No. 1048, 1-17-89; Ord. No. 1745, § I, 6-7-99; Ord. No. 1929, §§ I, II, 8-5-02)

**Cross References:** Utilities, ch. 28.

### **Sec. 32-39.1. Bicycle facilities.**

The requirement for the provision and construction of bicycle facilities, i.e. multi-use paths and/or bike lanes, shall be guided by the bicycle facilities and system master plan. Multi-use paths shall be constructed on the north side of east/west roadways and on the east side of north/south roadways. When the provision of said facilities is required, the subdivider shall be responsible for 100 percent of the required improvements within the boundaries of the development and 50 percent of any required improvements adjacent to the development. Low density local and minor local road classifications may be designated as bicycle facilities if necessary to complete a bicycle route system within the city.

(Ord. No. 1745, § I, 6-7-99)

**Sec. 32-40. Details.**

Details referred to in this division shall be as follows:

Title	No.
Standard Street Section:	
Minor local for residential lots less than 0.5 acre (1A and 1B)	S-1
Minor local for residential lots less than 0.5 acre (1C)	S-2
Minor local for residential lots of 0.51 to 1.00 acre	S-3
Minor local for residential lots 1.01 to 4.99 acres	S-4
Minor local for residential lots 5 acres or greater	S-5
Major local	S-6
Minor and major collector	S-7
Cul-de-sac detail	S-8
Curb and gutter details	S-9
Curb and gutter details	S-10
Typical wheelchair ramp detail	S-11

(Ord. No. 949, § 2.5, 9-8-87)

**Secs. 32-41--32-70. Reserved.**



## ARTICLE III.

### DRAINAGE\*

---

\* Cross References: Drainage and flood control, Ch. 34.

---

#### DIVISION 1.

#### GENERALLY

**Secs. 32-71--32-100. Reserved.**

#### DIVISION 2.

#### URBAN DRAINAGE CRITERIA

##### **Sec. 32-101. Introduction.**

This division contains guidelines for drainage system design and establishes a policy for recognized and established engineering design of storm drain facilities to protect the health, safety and welfare of the general public. Methods and processes included in this division are intended to serve as minimum standards. Recognized and established engineering practices and principles shall be followed in all engineering projects within the city and the five-mile planning and platting jurisdiction (ETZ). The Public Works Director of the city shall determine the required parameters of any particular project or technical analysis and may require additional criteria should such be deemed to be in the best interest of the general public.

(Ord. No. 949, § 3.1A, 9-8-87; Ord. No. 1224, § 1, 3-18-91)

##### **Sec. 32-102. Hydrology Storm definitions.**

(A) *Initial and major design storm.* For the purposes of this division, every urban area has two separate and distinct storm events. One is the initial or ordinary storm system corresponding to a 10% chance (10-year, 24-hour) storm in any given year. The other is the major, or extraordinary, storm which corresponds to a one percent chance (100-year, 24-hour) storm in any given year. Since the effects and routing of storm waters for the major 1% chance, 24-hour storm may not be the same as for the initial 10% chance, 24-hour storm, all storm run-off drainage plans submitted for review and approval shall indicate the effects of the initial and the major storm.

(1) *Initial 10% chance, 24-hour storm system.* The 10% chance storm drainage system shall be so designed as to provide protection against regularly occurring damage, to reduce street maintenance costs, and to provide orderly urban drainage ways.

- (2) *Major 1% chance, 24-hour storm system.* The major storm drainage system shall be so designed as not to cause property damage or loss of life from the runoff expected in a major storm event. The anticipated effects of the 1% chance storm on the 10% chance storm drainage system shall be clearly identified in the drainage report.
  - (3) *Historic Flow.* The historic flow shall be defined as the peak flow rate of storm water that enters, crosses and/or exits a proposed development in its pre-developed and undisturbed condition for both the initial (10% chance) and major (1% chance) storm events. It shall be the responsibility of the developers/owners engineer to show that peak flow and volume from a proposed development or construction project does not adversely affect or impact any upstream or downstream property, up to and including the next major drainage facility, drain and/or regional ponding area as determined by the Public Works Director or his designee. The development must not increase the peak, volume or change the location of the historic flow unless specifically allowed by the Public Works Director.
- (B) *Design storm frequencies.* The initial 10 year/10% chance and major 100 year/1% design storms shall apply to all land uses including but not limited to residential, Planned Unit Development (PUD), general commercial, parks, and open channels.
- (C) *Runoff computation.* Total storm runoff shall be computed in accordance with the criteria set forth in this division. Runoff computations for both the 10% chance and 1% chance storm shall be submitted with the proposed storm drainage plan. The most recent official Federal (ACOE, FEMA, FIS, USDA, USGS, etc...) data and references must be used when analyzing flow that crosses any site.
- (D) *Major Arroyo Crossings* Roadway crossing of major arroyos by Arterials will be done through a shared cost allocation process between the City and major developers in affected areas.

For purposes of this section, the term “major arroyo” shall mean any channel or waterway whose watershed exceeds 1.5 mi<sup>2</sup> (2.6 km<sup>2</sup>) and larger or a flow of 1000 cfs (28.31 m<sup>3</sup>/s) and larger in a 1% design storm whether such watershed is in its natural or unaltered state or has been altered by approved development, runoff diversions, or detention facilities.

(1) Funding Contributions:

Funding may be provided by the City for participation if such arrangements have been made and approved by the City Council as part of the City’s current or proposed budget process. Funding for Arroyo crossings will be considered by the City Council during the Master Plan

proposal phase as well as the Master Plan Stage when a resultant imminent public benefit will be realized by creating a critical link in the major transportation system as defined by the City and the Metropolitan Planning Organization.

The amount of the City participation in construction of such arroyo crossings may be established up to 50% of the construction and inspection cost. Adjustments to this value may be warranted from time to time and may be deviated from upon recommendation and justification from the Public Works and approval by the City Council.

If development is proposed where traffic generated by such proposal is without measurable public benefit, as determined by the City, then the developer will be responsible for full arroyo crossing construction. In circumstances where the City determines there is no public benefit to build an arroyo crossing, developers may be required to build the complete arroyo crossing at the time of their development.

A formal request, in the form of a proposal, is required during the Master Plan phase when City participation is requested. When more than one developer is involved it is the responsibility of the party requesting City participation to acquire support from all parties involved.

(2) Funding Alternatives:

There are two alternate methods for achieving cost contribution by the City for such major arroyo crossings. In both scenarios, the developer will be responsible for paying for and providing the design of the improvements for review and consideration by the City.

- (a) Pro-rata construction cost paid by developer to the City.
- (b) Design and participation in a voluntary Special Assessment District (S.A.D.) in conformance with New Mexico Law.

(3) Design Considerations:

- (a) The Developer will be responsible for providing the engineering, design, flood mapping revisions and associated costs (if needed).
- (b) In consideration for City participation, the developer must coordinate the design elements with City Public Works staff to ensure cohesion to regional open space and multi-use paths and alignments.

(Ord. No. 949, § 3.1B, 9-8-87)

Cross References: Definitions generally, § 1-2.

**Sec. 32-103. Runoff analysis methods.**

- (A) *Applicability.* This section sets forth the minimum design, technical criteria and specifications for the analysis and design of drainage systems. All subdivision construction plans, planned unit developments, paving projects, or any other commercial or residential construction submitted for approval by the city shall include storm drainage analysis and appropriate system design before any phase of construction will be permitted. Such analysis and design shall meet the criteria outlined in this article and must be approved by the Public Works Department before a permit is issued.
- (B) *Development of less than three acres.* (0.00 to 2.99 Acres) (0.00 to 1.21 ha) Runoff analysis for developments of less than three acres can be based on general runoff coefficients for valley and/or mesa areas. The runoff coefficient is a value that is used to approximate the amount of runoff that a developer or home builder will need to retain on site to maintain existing drainage characteristics. Drainage plans based on the Soil Conservation Service (SCS) method, in lieu of this simplified approach, will be acceptable. SCS submittals should include all supporting documentation, soils maps, CN tables, etc. Any site with a channelized flow crossing the site must use the SCS method. Developments within the 100 year flood plain must comply with Las Cruces Ordinance No. 1933. Specific requirements shall be as follows:
- (1) Identify area classification.
    - (a) Valley areas, land slope less than one percent.
    - (b) Mesa areas, land slope greater than or equal to one percent.
  - (2) Runoff & Flow coefficients.
    - (a) Valley areas runoff, 2.8 inches. (71.12mm)
    - (b) Mesa areas runoff, 2.0 inches. (50.80mm)
    - (c) Flow coefficient, 1.6 cfs/acre-in. (.004408 M<sup>3</sup>/(s\*ha\*mm))

	$A * F_c * R_c = Q = \text{flow rate}$
English	$\text{Impervious Area(acre)} * \text{Flow Coefficient (CFS/acre-in)} * \text{Runoff Coefficient (in)} = \text{Peak Flow Rate (CFS)}$
Metric	$\text{Impervious Area(ha)} * \text{Flow Coefficient (M}^3\text{/(s*ha*mm))} * \text{Runoff Coefficient (mm)} = \text{Peak Flow Rate (M}^3\text{/sec)}$

- (3) Calculate impervious area of land to be developed. Impervious area includes the building, sidewalks, asphalt paving, etc. (Places where water

cannot penetrate into the ground, including some desert landscaping.)  
Calculate area in square feet (square Meters).

- (4) Find required storage volume by multiplying the impervious area (square feet) (or square meters) by the runoff coefficient (inches or millimeters) and a conversion factor 1 foot /12 inches. (1 meter/1,000 millimeters)

	$A * C_R * CF = SV = \text{Storage Volume}$
English	$\text{Area}(FT^2) * \text{Runoff Coefficient (in)} * \text{Conversion factor (1ft/12in)} =$ <div style="text-align: right;">Required Storage Volume (FT<sup>3</sup>)</div>
Metric	$\text{Area}(m^2) * \text{Runoff Coefficient (mm)} * \text{Conversion Factor (1m/1,000mm)} =$ <div style="text-align: right;">Required Storage Volume (M<sup>3</sup>)</div>

- (5) Indicate on the construction plans how the required storage volume will be controlled on site. Include details on wall and berms that will control or direct runoff, asphalt and lots grade, and method of overflow of the storage area.

- (6) Acceptable types of drainage structures are as follows

(a) *Open ponding.* Open retention ponds are recommended in areas that have good percolation of water into the soil. Open ponds offer the maximum amount of storage for a given land area. The minimum depth shall be 18 inches (0.46m), and the pond shall be located a minimum of five (5) feet from adjacent property lines and 10 feet (3.05m) from any structures. The design parameters are further defined in section 32-107.

(1) *French drain.* French drains are acceptable in areas that have poor percolation rates, i.e., clay. A French drain shall be used only to provide increased percolation rates for runoff. French drains must have an open pond above rock level with a minimum clearance of 12 inches (0.30m) between grate and top of rocks.

(a) *Underground storage.* Underground storage is recommended in areas with good percolation and limited space. Credit is given for the open volume only; no credit is given for rock voids. No credit will be given for “rock ponds”. Some acceptable products include, but are not limited to, perforated CMP, perforated HDPE,

Rainstore©, infiltrator systems, etc. Designs must include a method to maintain the structures effectiveness.

(C) *Development equal to or greater than three acres.* For development equal to or greater than three acres (1.214ha), the following shall apply:

(1) Runoff analysis for developments equal to or greater than 3.0 acres (1.214ha) shall be based on the Soil Conservation Service (SCS) method which is outlined in a publication entitled "Peak Rates of Discharge for Small Watersheds, Chapter 2 (revised 2/85 for New Mexico), Engineering Field Manual for Conservation Practices." This manual is specifically for the application of the SCS procedure in New Mexico. Rainfall data for analysis can be obtained from the City of Las Cruces Public Works Department. The City of Las Cruces requires the use of a modified S.C.S. Type II Storm with a minimum of 75% of rainfall occurring in a one-hour period. The following limitations apply to the SCS method:

- (a) Minimum initial time, five (5) minutes. (Not  $T_c$ )
- (b) Time of concentration ( $T_c$ ) is equal to the sum of initial time and gutter/pipe flow time. However, engineers must calculate the time of concentration. Time of concentration used shall be calculated value or six minutes, whichever is greater. All calculations must be included in the drainage report.
- (c) Overland flow portions of time of concentration are to be calculated for a maximum reach length of 500 feet. (152.4m)
- (d) Curve Numbers (CN's) shall be from USDA SCS, TR 55, 1986 or newer tables. CN's for residential or commercial/industrial uses shall be calculated using actual hydrologic conditions. CN's must be rounded to the nearest whole number.

(2.) *Specific requirements.* The following criteria shall be utilized in the analysis of the drainage system:

- (a) Runoff analysis shall be based upon the proposed land use, and shall take into consideration all contributing runoff from areas outside of the study area. The analysis of storm runoff from undeveloped and existing developed areas lying outside of the study area shall be based upon present land use and topographic features.
- (b) The probable future flow pattern in undeveloped areas shall be based on existing natural topographic features (existing slopes, drainage ways, etc.).

- (c) Average land slope in both developed and undeveloped areas may be used in computing runoff. However, drainage patterns and slopes that have already been established shall be used in areas where available.
- (d) Flows and velocities which may occur at a design point when the upstream area has been fully developed shall be considered. Drainage ways, including the 10% chance and 1% chance systems shall be designed such that the increased flows and velocities, due to development, meet the guidelines for the 10% chance and 1% chance design storms.
- (e) Streets can be used as drainage ways for the 10% chance storm runoff. The primary use of streets shall be for the conveyance of traffic.
- (f) On-site retention or detention is required for all sites. Detention Ponds must detain the 1% chance rainfall allowing the predeveloped flow or less to flow off the development. An approved routing system must be used to route the hydrograph through the detention pond(s). Detention pond storage volumes shall be calculated for the ten (10% chance) and 100-year (1% chance) storms by flood routing using a hydrographic method (HEC-1, HEC-HMS, SCS Hydro, TRSS, or generally recognized method) or by the FAA method. The changing of a natural drainage way location will not be approved unless such change is shown to be without unreasonable hazard and liability, substantiated by thorough analysis and investigation of all affected down stream facilities. This includes impacts to buildings, public and private infrastructure, habitats and, open space. The use of detention facilities may not be acceptable where outfall is into another storage facility. When the peak flow and total volume into the storage facilities is greater than the pre-development peak flow and total volume, a detailed hydrologic analysis of both facilities must be provided to the City for review. These facilities may be sensitive to increased volumes of runoff as opposed to increase rates of flow. Such facilities require approval of the Public Works Director.
- (g) The planning and design of drainage systems shall be such that problems are not transferred from one location to another. Outfall points shall be designed in such a manner that will not cause increased flooding and/or erosion downstream. Irrigation canals shall not be used as outfall points unless such is shown to be without hazard substantiated by thorough hydrologic and hydraulic analysis. Approval for use of irrigation canals for drainage shall be



obtained in writing from the controlling agency and shall be submitted to the city as part of the drainage study.

- (h) Floodplain information shall be required along with a Conditional Letter of Map Revision (CLOMR) and a Letter of Map Revision (LOMR) for one percent (1%) chance for storm flows of greater than 250 cfs (2.83 M<sup>3</sup>/S), developments of 5 acres and larger, developments with 50 or more lots, and/or developments with any changes to the existing flow path in FEMA flood hazard zones AE, A, AH, AO, and D upon the submittal of any on preliminary and/or final drainage drawings for review. Information shall include peak discharges for the ten percent (10%), two percent (2%), one percent (1%) percent and two-tenth percent (0.2%) chance storms for the floodplain inundation area and anticipated depth of floodwaters one foot(1') and deeper. Standard step backwater models shall be used for flood depth determination. The Hydrologic Engineering Centers HEC-2 analysis method may be required. Improvements and subdivisions will not accepted by the City until the FEMA flood study has been approved by FEMA.

A CLOMR will be submitted for review by the City and submitted to FEMA prior to plan and/or final plat approval.

A LOMR will be submitted for review by the City and submitted to FEMA before acceptance by the City and before the issuance of any Certificate of Occupancy. Costs incurred for the preparation of materials and fees paid to FEMA will be borne by the developer.

- (i) Dedicated drainage easements or rights-of-way are required for drainage ways, and these shall be designated on all drainage drawings and subdivision plats. Drainage rights-of-way dedicated to the City shall have a minimum clear bottom width of 15 feet (4.57m) of clear unobstructed space with a design that facilitates cleaning using available equipment.
- (j) Approval will not be made for any construction which will encroach on any drainage easement or impair surface or subsurface drainage.

(Ord. No. 949, § 3.1C, 9-8-87; Ord. No. 1224, § 1, 3-18-91)

**Sec. 32-104. Specific analysis requirements.**

(A) *Requirements for storm drainage reports and construction plans.* All drainage reports shall be prepared by a professional engineer, registered in the State of New Mexico, and shall comply with the minimum requirements and specifications set forth in this section. Review schedules will be as outlined in the subdivision and building codes. However, reports involving large developments and complex structures will require more review time. The engineer should be aware that whenever unusual or serious drainage problems are anticipated in conjunction with a proposed development, additional analysis and information beyond the minimum requirements outlined in this section may be required by the Public Works Director or his designee of the City. The following specifications and criteria shall be used:

(1) *Master drainage study.*

(a) A master drainage study shall be required prior to approval for any annexation, planned unit development, or subdivision preliminary plat. The purpose of the master drainage study is to identify major drainage ways, ponding areas, locations of culverts, bridges, open channels and drainage basins which are contributory to the proposed study area. In addition, the ability of downstream drainage facilities to pass the developed runoff from the proposed development must be analyzed in the master drainage study. The master drainage study shall contain a general outline of the proposed drainage routing plans for the development. The report shall include but not be limited to the following information and calculations:

- (1) Calculations for peak flow from all upstream off-site tributary drainage areas.
- (2) Calculations for peak flow within the proposed development for all drainage basins larger than 20 acres (8.09 ha).
- (3) Preliminary analysis of the one percent (1%) and ten percent (10%) chance storm floodplain and major drainage ways.
- (4) Closed subbasin analysis including identification of water into or out of subbasin.
- (5) Discussion and analysis of downstream drainage facilities.
- (6) Discussion of drainage problems and solutions which

are anticipated within the proposed development.

- (7) The report shall be printed and bound on 8 1/2-inch by 11-inch paper.
  - (8) All drainage studies/reports must include a table of pertinent values in the body of the report. The values shall include, at a minimum, flow depth for all flow paths, peak velocity,  $T_c$ , freeboard for channels (not including streets), flow (Q), CN numbers, and volumes of runoff for basins. Drainage studies shall include maps showing both flow and volume into and out of basin(s) and proposed development.
  - (9) Flows may need to be routed to a historic point of convergence for both the pre and post condition.
- (b) Drawings for the master drainage study shall include but not be limited to the following:
- (1) Any and all floodplains and floodways must be identified. A copy of the applicable FEMA floodplain map is required indicating limits of current study.
  - (2) Existing topography, two (2) foot (0.5m) contour interval minimum.
  - (3) Location and size of existing and proposed open channels, storm drains, detention/retention areas, SCS soils map, and all other drainage structures.
  - (4) Identification of all drainage basins in the development.
  - (5) Location of all streets larger than residential classification.
  - (6) Identification of all drainage basins tributary to the proposed development.
  - (7) Basin maps may be scaled as small as 1"=600' (1:7200). Orthophoto maps at a scale of one inch equals 200 feet are preferred. Basin maps shall have each basin name, Area (acres), 10% & 1% peak flows (CFS) into and out of the basin (shown at the location of concentration) and, clearly indicated flow paths. Maps of a scale 1"=2000' may be used for undeveloped, offsite basins greater than 1 square mile.

- (8) All maps shall be a minimum of 24" x 36" and shall be professionally incorporated within the report. Pre-printed maps, such as USGS maps, are acceptable if otherwise allowable. Maps of a smaller size may be accepted at the reviewer's discretion.
  
- (c) Inlet and storm drain size calculations are not required with the master drainage study; therefore, the number of sub basins analyzed in the report shall be held to the smallest practical number.
  
- (d) Recommended Outline. The following is a sample outline for a typical Master Drainage Report. Each of these headings should be addressed in the report body with supporting information and calculations in the appendices. Information provided at this stage of the review process is reviewed for ONLY the phase submitted for and ONLY for the requirements above. Post development items are considered conceptual during this review phase.
  - (1) Introduction & Purpose
  - (2) Methodology
  - (3) Scope of Investigation
  - (4) Meteorological & Geological
    - (a) Climate
    - (b) Rainfall
    - (c) Soil investigation
      - (i) Hydrologic soil classification
      - (ii) Runoff Curve Number
      - (iii) Soil Description
  - (5) Basins
    - (a) Basin parameters
  - (6) Hydrology
    - (a) Pre Development

- (i) Direct Runoff
      - (ii) Runoff Volume Computation
      - (iii) Peak flow computations
    - (b) Post Development
      - (i) Direct Runoff
      - (ii) Runoff Volume Computation
      - (iii) peak flow computations
    - (c) Comparison & ponding of pre & post development
  - (7) Hydraulics
    - (a) Natural & man-made channels
    - (b) Streets
    - (c) Culverts & Storm Drains
  - (8) Conclusion section
    - (a) Discussion of final drainage items
    - (b) Detailed description of hydraulic and hydrologic interaction.
  - (9) Appendices
    - (a) ALL required maps & drawings
    - (b) ALL calculations
    - (c) Input and Output from any modeling and routing software.
- (2) *Final drainage study.* The final drainage study shall be a detailed study and analysis of the drainage in the proposed development for both predevelopment and post-development conditions. Developments include but are not limited to subdivisions, commercial developments, or planned unit developments. It shall include detailed calculations for all runoff within the proposed development, and detailed calculations for all runoff

exterior to the site, with detailed calculations supporting the design of all drainage structures within the development. Final drainage studies shall use the approved methods as in section 32-103 C(2). Construction plans for all drainage structures, grading plans and street grades, where applicable, shall also be considered part of the final drainage study. Drawings and calculations comprising the final drainage study shall include but not be limited to the following information:

- (a) Clearly labeled existing and proposed contours for proposed development. (Contour interval based on USGS datum, two-foot (0.61 m) contour interval minimum.)
- (b) Location and elevations of city or USGS benchmarks. All elevations shall be based on USGS datum.
- (c) Property lines.
- (d) Streets, right-of-way limits, names and grades.
- (e) Existing drainage facilities and structures, including existing irrigation ditches, roadside ditches, drainage ways, gutter flow directions, and culverts. All pertinent information such as size, slope, and location of existing drainage ways shall be included to facilitate review and approval of drainage plans.
- (f) Overall drainage area boundaries and drainage sub area boundaries.
- (g) Proposed type of curb and gutter (vertical, combination, rollover, or flat) and gutter flow directions including crosspans (intersections).
- (h) Proposed storm drains, open drainage ways and right-of-way requirements, including proposed inlets, manholes, culverts, erosion control and energy dissipation devices, and any other required appurtenances necessary for drainage control.
- (i) Proposed inflow and outfall points for runoff from the study area.
- (j) Routing and combining all flows at various critical points for the initial 10% chance (ten-year) and major (1% chance, 100-year) storm runoff. Note: When a Storm Water Pollution Prevention Plan (SWPPP) or Erosion Control Plan is required, this evaluation is required for a 50% chance, 2-year storm during construction.
- (k) Minimum finished floor elevation and ground site elevations at all

critical building locations for protection from major storm runoff.

- (l) Predevelopment and post-development basin maps, with a scale of one inch equals 100 feet, (1:100) of the proposed development, which shall show the following information:
  - (1) Location and size of all drainage structures.
  - (2) General flow patterns and flow paths within the development also to include offsite basins affecting the development.
  - (3) Finished floor and ground site elevations of all buildings and adjacent Sites and Structures.
  - (4) One percent (1%) chance flood level in all streets in which the curb is overtopped during the one percent (1%) chance storm.
  - (5) All drainage basins within, and affecting, the development shown in a table listing basin names, basin area (acre), 10% and 1% peak flows into and out of each basin shown at the flow path location. Note: The number of basins should be limited to the smallest practical number.
- (m) All floodplains and floodways within the proposed development. A copy of the current FEMA floodplain map is required, showing project limits.
- (n) All drawings shall be on 24-inch by 36-inch (0.610x0.914m) sheets. Maps of a smaller size may be accepted at the reviewer's discretion.
- (o) SCS soils map showing project location.
- (p) Final Drainage Study shall incorporate Master Drainage Study
- (q) Recommended Outline. The following is a sample outline for a typical Final Drainage Report. Each of these headings should be addressed in the report body with supporting information and calculations in the appendices. Information provided at this stage of the review process is reviewed for ONLY the phase submitted for and ONLY for the requirements above.
  - (1) Introduction & Purpose

- (2) Methodology
- (3) Scope of Investigation
- (4) Meteorological & Geological
  - (a) Climate
  - (b) Rainfall
  - (c) Investigation
    - (i) Hydrologic soil classification
    - (ii) Runoff Curve Number
    - (iii) Soil Description
- (5) Basins
  - (a) Basin parameters
- (6) Hydrology
  - (a) Pre Development
    - (i) Direct Runoff
    - (ii) Runoff Volume Computation
    - (iii) Peak flow computations
  - (b) Post Development
    - (i) Direct Runoff
    - (ii) Runoff Volume Computation
    - (iii) Peak flow computations
  - (c) Comparison & ponding of pre & post development
- (7) Hydraulics
  - (a) Natural & man-made channels



- (b) Streets
    - (c) Culverts & Storm Drains
  - (8) Conclusion section
    - (a) discussion of final drainage items
    - (b) Detailed description of hydraulic and hydrologic interaction.
  - (9) Appendices
    - (a) ALL required maps & drawings
    - (b) ALL calculations
    - (c) Input and Output from any modeling and routing software.
- (3) *Plan details.* The following details shall be indicated on the drainage plans:
  - (a) Title block (lower right-hand corner preferred).
  - (b) Scale.
  - (c) Date and revisions.
  - (d) Name of professional engineer and firm.
  - (e) Professional engineer's seal.
  - (f) Drawing number (sheet n/n).
  - (g) Legend.
  - (h) Approval blocks for various city departments.
- (4) *Construction plans.* Construction plans shall show the following information:
  - (a) *Plan.*
    - (1) North arrow.

- (2) Property lines, adjacent property's, ownership thereof and subdivision information.
  - (3) Street names and easements with width dimensions and location.
  - (4) Existing utility lines, location and depth, or height, as follows:
    - (i) *Water.*
    - (ii) *Gas.*
    - (iii) *Telephone.*
    - (iv) *Storm drains.*
    - (v) *Irrigation canals.*
    - (vi) *Sanitary sewers.*
    - (vii) *Other utilities.*
- (b) *Profile.*
- (1) Vertical and horizontal grids with scales.
  - (2) Ground surface grade (dashed) and proposed grade (solid).
  - (3) Existing utility lines where crossed.
  - (4) Benchmarks (USGS datum).
- (c) *Proposed construction.*
- (1) *Pipes and culverts.*
    - (i) Plan showing stationing.
    - (ii) Profile.
    - (iii) Size, length between manholes, and pipe composition.
    - (iv) Grades of pipe.

- (v) Inlet and outlet details of all manholes and inlets, and connections to existing drainage systems.
- (vi) Manhole details including station numbers and invert and top elevations.
- (vii) Typical bedding details for pipe for all bedding situations encountered on project.

(2) *Open channels.*

- (i) Plan showing stationing.
- (ii) Profile indicating grade of invert of channel, top of lining if any and adjacent ground grade.
- (iii) Typical cross sections.
- (iv) Construction notes.
- (v) Lining details.
- (vi) Riprap and bedding details, gradation requirements for same.
- (vii) Structure details of all inflow, outflow and drop structures. Including sub grade and foundation design details.

- (3) *Technical specifications.* Technical specifications shall be included on any drainage project that is permitted for construction within the city. Specifications shall meet the minimum guidelines for construction as outlined in the city standard specifications for roadway construction.

Additional specifications for construction shall be included to the point that there exists a clear understanding of the nature and quality of work to be performed on the project. The City may request additional technical specifications for projects that will become City property or will be involved in the storm drainage maintenance program.

- (B) *Construction approval.* Record drawings of improvements shall be provided for all subdivision or public right-of-way construction projects. The design engineer and the City must review and approve any changes to the original design of a project. Record drawings will be made by the design engineer from information provided by job-site contractors or field surveys. Upon obtaining the record drawings, final inspection, Letter of Map Revision (when applicable), and

approval by the Public Works Director or his/her designee, the project can be issued a letter of acceptance or the improvement can be accepted by the city in the case of a subdivision or planned development.

- (C) *Sediment transport.* Moving water has the ability to transport sediment. The amount of sediment per unit of water that can be transported is related to flow depth, velocity, temperature, vertical and horizontal channel alignment, the amount of sediment available, the size and density of sediment available and many other minor but sometimes important parameters. A channel's stability can be defined in terms of its ability to function properly during flood events without serious aggradation or degradation and that its continued operations can be relied upon without extraordinary maintenance and repairs. While channel stability problems are largely associated with earth and flexible material linings, concrete lined supercritical channels are not immune. Any time a downstream channel reach has a lower sediment capacity than an upstream portion, there is a potential for sediment accumulation. Recommended design aids for sediment transport in the Southwest Region is a report written by Simons, Li and Associates for the City of Aurora, Colorado entitled *Drainage and Flood Control, Design Guidelines and Criteria, Channels and Hydraulic Structures on Sandy Soil* dated June 1981. Another resource is the *Sediment and Erosion Design Guide* prepared for AMAFCA by RCE of Fort Collins, Co March 1994. These reports are used by many Southwest cities and is recommended for use in the City for analysis of drainage.
- (D) *Construction Site Discharge.* The Environmental Protection Agency (EPA) has determined that construction can cause up to ten times the sediment and pollutants to leave a site during a rain event. As a part of the Clean Water Act, the EPA mandates that all construction which clears at least one (1) acre of ground, (or is part of a larger development, like a subdivision) comply with the Construction General Permit). The EPA also Mandates that the City of Las Cruces keep pollutants including sand and debris out of streets and storm drains. All construction sites and subdivisions one (1.00) acres (.405 ha) and greater in size under development in the City of Las Cruces shall provide a site erosion control plan when subject to the EPA Construction General Permit. The erosion control plan shall include temporary ponding, site stabilization, silt fences, berms etc. as necessary to control site erosion and eliminate sediment transport to downstream lands or right-of-way or offsite (i.e. adjacent streets). Ponding volumes for SWPPP preparation shall be based on a minimum of a 2-year storm event and associated runoff. The disturbed area of the construction site shall be taken into account when determining the methods to control site erosion. Structures or measures to improve storm water quality to City drainage systems in accordance with the City's stormwater management plan must be shown on both residential and commercial subdivisions plans.

The *National Pollutant Discharge Elimination Manual Storm Water Management Guidelines for Construction and Industrial Activities* provides the appropriate

methodology for use in New Mexico and is recommended for use in developing the Erosion Control Plan and Storm Water Pollution Prevention Plan (SWPPP), however any Best Management Practices (BMP) may be submitted for review. The City of Las Cruces reserves the right to review the SWPPP for any development. A SWPPP must be acceptable to the regulatory agency prior to any land disturbance activity or permit issuance.

See City of Las Cruces Municipal Code Ordinance 2146, Section SEC. 34-133. Storm Water Discharge from Construction Activities for specific design requirements.

- (E) *Undeveloped System Outlets.* Site developments and subdivisions one (1.00) acre (2.02 ha) and greater in size that discharge storm runoff to an undeveloped or 'natural' drainage system shall be designed to minimize the impact of developed 'clean' runoff on the downstream system. The development plans shall include an analysis of the proposed site discharge and the method(s) to limit the downstream erosion to the minimum practical extent. In general, flow rates must be limited to a non-erosive level, see Table 32-105.5.C. It shall be the responsibility of the owner to maintain all proposed erosion and sediment control devices in proper functioning order. If and when a downstream system is developed to a point that downstream erosion is not a concern, the development may abate the measures to limit storm run-off to less than the historical discharge rate.
- (F) *Undeveloped System Inlets.* In a location where an inlet will allow a natural flow to enter the development, permanent BMP's must be in place to remove silt and floatable material from entering the developed area while safely allowing historic flow. Such inlets must facilitate ease of maintenance.
- (G) *Erosion Control Plan Review.* The erosion control plan for construction sites and for undeveloped system outlets may be prepared by the developer, if the project is less than five acres (0.00) – 4.99 ac) (2.01 ha) in size, is not a designated flood plain, and does not have a major arroyo crossing the site. All other sites shall be prepared by a registered professional engineer, licensed in the State of New Mexico. All erosion control plans will be reviewed by the City of Las Cruces Public Works Department. Failure to implement effective best management practices outlined in the erosion control plan or the SWPPP may result in a stop work notice on construction sites.

(Ord. No. 949, § 3.1D, 9-8-87)

**Sec. 32-105. Hydraulics of storm drainage systems.**

(A) Allowable Pavement Encroachments

*Street flow capacities.* For the purpose of this division, both the 10% chance and 1% chance storm runoff must be considered, and calculations showing storm runoff at critical sections shall be submitted. The following criteria shall apply in the determination of allowable street flow capacities:

- (1) *Initial (10% chance) storm street capacities.* Pavement encroachment for the initial design storm shall not exceed the limitations outlined in the following table:

**ALLOWABLE PAVEMENT  
ENCROACHMENT**

**DEPTH OF RUNOFF FLOW FOR 10% CHANCE STORM**

<b>Street Classification</b>	<b>Maximum Encroachment</b>
Local	No curb overtopping, flow may spread to crown of street
Collector	No curb overtopping, flow spread must leave the equivalent of one 10-foot (3.3m) driving lane clear of water
Arterial (Minor & Major)	No curb overtopping, flow spread must leave the equivalent of two, 10-foot (3.3m) driving lanes clear of water. One lane in each direction
Freeway	No encroachment allowed on any traffic lane

The 10% chance storm drainage system shall commence at a point where the maximum allowable encroachment occurs.

- (2) *Major (1% chance) storm street flow capacities.* The allowable depth of flow and inundated area for the major storm runoff shall not exceed the limitations outlined in the following table:

**ALLOWABLE PAVEMENT ENCROACHMENT  
DEPTH OF FLOW AND INUNDATED AREA FOR  
MAJOR STORM RUNOFF**

Street Classification	Allowable Depth and Inundated Area
Local and collector	Residential dwellings, public commercial and industrial buildings shall not be inundated at the ground line unless buildings are flood proofed. The storm runoff shall be contained within the right-of-way
Arterial	Residential dwellings, public, commercial and industrial buildings shall not be inundated at the ground lines unless buildings are flood proofed. Depth of water at the street crown shall not exceed six inches (0.152m) to allow operation of emergency vehicles. The depth of water over the gutter flow line shall not exceed 12 inches (0.305M). The storm runoff shall be contained within the right-of-way
Freeway	No water on crown of street

- (3) *Cross Street flow capacities.* Cross street flow can occur by two separate means. One is runoff that has been flowing in a gutter and then flows across the street to the opposite gutter, outlet, or inlet. The second case is flow from an external source, such as a drainage way or conduit, which will flow across the crown of a street when the conduit capacity is exceeded. The maximum allowable cross street flow depth based on the worst condition shall not exceed the limitations stipulated in the following table:

**ALLOWABLE CROSS STREET SECTION FLOW**

Street Classification	Initial Storm Runoff 10% chance, 24-hour	Major Storm Runoff 1% chance, 24-hour
Local	3 inch (0.076m) depth at crown	6 inches (0.16m) of depth above Crown.
Collector	Depth of flow shall not exceed 3 inches (0.076m), at crown.	6 inches (0.16m) of depth above Crown.
Arterial	None	None.
Freeway	None	None

\*Cross Street velocity should not exceed 10 Ft/sec unless approved by Public Works Director.

(B) *Storm drains and storm inlets.*

Storm drains and inlets shall be of sufficient capacity to adequately convey the expected runoff from the 10% chance design storm. The storm drain system and subsequent storm inlets shall commence at all locations where the allowable street capacity is exceeded or at locations where ponding of water is likely to occur.

- (1) *Minimum pipe diameter.* The minimum allowable pipe size to be used in storm drains and laterals is as follows:

**MINIMUM ALLOWABLE PIPE SIZE**

Type of Conduit	Minimum Pipe Diameter
Main trunk	24 inches (0.610m)
Individual laterals (to drop inlets)	18 inches (0.457m)

Elliptical or arch pipe will be allowed where design conditions dictate, provided that the cross sectional area of the arch pipe is not less than the area of the conduits listed above.

- (2) *Allowable pipe materials/applications.* Allowable pipe materials and applications are as follows:

- (a.) HDPE (First and last joint shall be Concrete or CMP where pipe exits soil if no drop inlet)
- (b.) Reinforced concrete pipe, class III
- (c.) Corrugated metal pipe: application is dependent on soil conditions and pipe application.
- (d.) Life expectancy of all pipe shall be 20 years minimum based on designed usage.

Note: All pipes and conduits must be designed to withstand all structural loads (dead load and live load). New Mexico Department of Transportation standards shall be considered as a minimum guideline for the basis for design. Storm Drains and culverts shall not have a cover depth of less than two feet (2') of finished grade at any point unless design analysis and conditions of site dictate otherwise.

- (3) *Manhole spacing.* The maximum allowable spacing between manholes or other provisions for cleanouts shall not exceed those listed in the following table:



**MAXIMUM ALLOWABLE MANHOLE  
SPACING**

<b>Pipe Diameter</b>	<b>Maximum Allowable Spacing Between Manholes and Cleanouts</b>
24—36 in (0.610M-0.914M)	400 Feet (122M)
42—60 in (1.061M-1.52M)	500 Feet (152M)
Greater than 60 in (1.524M)	750 Feet (228M)

Manholes shall be placed at any change in grade or direction and at all connections unless approved by the Public Works Director. The storm drain system should be placed under the roadway. Alternate locations may be approved by the Public Works Department if conditions prevent standard location.

- (4) *Calculation of flow capacities in drainage conduits.* The capacities of conduits shall be computed using Manning's formula, appropriate flow nomographs, or approved computer modeling program. The value of the roughness coefficient (n) to be used shall not be less than those specified in the following table. The average full-flow velocity in conduits shall not be less than two feet/second (0.61m/s). Included in the table are roughness coefficients that can be used in open channel flow calculations.

**THIS SPACE INTENTIONALLY LEFT BLANK**

## VALUES OF N FOR THE MANNING FORMULA

Flow Condition		N
Plastic pipe, PVC, HDPE		0.009
Smooth metal		0.010
Ordinary concrete		0.013
Asphalted cast iron		0.013
Vitrified clay		0.014
Cast iron pipe		0.015
Concrete pipe		0.015
Brick, dressed stone		0.016
Smooth earth		0.018
Firm gravel		0.020
Corrugated metal pipe		0.023
Natural channels:		
	Clean, straight, no pools	0.029
	As above, with weeds and stones	0.035
	Winding, pools and shallows, clean	0.039
	Very weedy and sluggish	0.112
Lined channels:		
Concrete surface (bottom and sides):		
	Smooth finish	0.015
	Unfinished	0.017
	Curb and gutter	0.021
Concrete bottom with sides:		
	Mortared stone	0.020
	Dry rubble or riprap	0.033
Asphalt:		
	Rough	0.016
	Smooth	0.013

Values quoted in this subsection are averages of many determinations; variations of up to 20 percent must be expected, especially in natural channels.

- (5) *Storm drainage inlets.* Storm drainage inlets shall be a grate, curb opening or combination inlet. Combination curb/gutter inlets shall be used at all points where ponding or sump conditions exist. The theoretical capacity and spacing of storm inlets will be analyzed using the criteria outlined in these specifications. The allowable capacity will be determined using the reduction factors listed in the following table. These reduction factors compensate for debris plugging, pavement overlaying, variations in design assumptions and other factors that decrease capacities.

The size of outlet pipes from stormwater inlets shall be based upon the theoretical capacity of the inlet, but in no case shall pipes be smaller than 18 inches (0.457m) in diameter.

### INLET REDUCTION FACTORS

Condition	Allowable Inlet Type	Percent of Theoretical Capacity Allowed	Calculation
Sump and continuous grade	Combination curb opening with grate	65	0.65*QT
	Curb opening only	85	0.85*QT
	Grate only	50	0.5*QT

\*QT is the theoretical flow through the inlet.

Computations for storm drain and inlet design capacities shall be submitted as part of the final drainage study. Adequate details of the proposed storm drain system; inlets and manholes shall be included in the drainage report and detail drawings within the plan set. Theoretical flow capacities shall be reduced by the reduction factors outlined in this subsection to obtain design flow capacities.

(C) *Crossing structures and culverts.*

Crossing structures and culverts shall convey the one (1) percent storm through the structure with additional design that provides for overflow capacity if the structure capacity is reduced due to trash or debris accumulation. Culverts under major arterials shall have sufficient capacity to pass the runoff from the major storm considering that 20 percent of the inlet is plugged. All other culverts shall be designed with emergency overflow that will help convey the major storm event. Capacities shall be calculated for the inlet, pipe, and outlet control conditions where the most conservative condition shall be used. In determining the amount of overflow required, the following capacity credit shall apply:

### CAPACITY CREDIT FOR STRUCTURES

Cross Section Area of Structure	Capacity Credit Percent of Full Flow Capacity	* Percent of Major Storm Flow to be Considered as Emergency Overflow
Less than 20SF (1.858m <sup>2</sup> )	50	50
Greater than 20SF(1.858m <sup>2</sup> )	80	50

\* Shall meet street cross flow requirements of this section.

$Q_t * [\text{Capacity Credit}]$  equals allowed structure capacity.

The appropriate amount of emergency overflow onto streets shall be taken into account when analyzing storm runoff and allowable street capacities for the major storm. The following design criteria should be used for all culvert design:

- (1) *Culvert.* The culvert, including all inlet and outlet structures, shall properly take care of water, bed load and debris at all stages of flow.
- (2) *Inlets.* Culvert inlets shall be designed to minimize entrance and friction losses. Inlets shall be provided with either flared end sections or headwalls with wing walls and adequate rip-rap protection. Projecting ends will not be acceptable. For large structures, provisions shall be made to resist possible structural failure due to hydrostatic uplift forces. Structure shall be reinforced concrete with removable, lockable grates.
- (3) *Outlets.* Culvert outlets shall be designed to avoid sedimentation, undermining of the culvert or erosion of the downstream channel. Outlets shall be provided with either flared end sections or headwalls with wing walls, aprons (containing energy dissipaters), and toe walls. Additional outlet control in the form of riprap, channel shaping, etc., shall required where excessively high discharged velocities occur, see Table 32-105.5.C. Outlets shall have removable galvanized steel grates to facilitate cleaning (rebar racks are not acceptable). No sharp energy dissipaters will be permitted.
- (4) *Slopes.* Culvert slopes should be such that neither silting nor excessive velocities and scour occur. Generally the minimum slope of culverts shall be 0.5 percent.
- (5) *Headwater.* Generally the headwater to diameter ratios should not exceed the following:

**RECOMMENDED MAXIMUM  
HEADWATER TO  
DIAMETER RATIOS**

<b>Storm Frequency</b>	<b>HW/D</b>
(10% chance storm)	1.0
(1% chance storm)	1.25

Excessive ponding above culvert entrances will not be acceptable if such ponding appears likely to cause property or roadway damage, culvert clogging, saturation of fills, detrimental upstream deposits, or inundate existing or future utilities or structures.

- (6) *Tail water.* The height of tail water at outlets shall be subject to the criteria listed under headwater criteria above.
- (7) *Rip-Rap* – The construction of rip-rap surface treatment shall consist of furnishing and placing stone, with or without grout, and with or without wire mesh. Cutoffs shall be provided, to a minimum thickness of three (3) times the required apron thickness, at both the upstream and downstream terminals of the rip-rap apron when a stable feature is not present (i.e. concrete cutoff wall). All rip-rap shall have either a filter material (FM) or a non-woven geotextile between the soil and rip-rap, except where rip rap is grouted. Wire-tied rip-rap shall have stakes and conform to NMDOT serial BRR-001-08. The rip-rap used shall conform to the following:

### MINIMUM RIP-RAP REQUIREMENTS

<b>Water Velocity Fps (m/s)</b>	<b>Weight of Rock lb (kg)</b>	<b>Apron Thickness in (mm)</b>	<b>Rip-Rap Designation</b>	<b>Use</b>
N/A	NA	T/2	Type FM (Filter Material)	Filter Material Only
By Design	30 (13.6)	By Design	Type WT** (Wire Tied)	Gabion
0-3.9 (0-1.2)	50 (22.7)	18 (457.2)	Type L (Very Light)	Gabion Or Loose
4-7.9 (1.2-2.4)	100 (45.4)	24 (609.6)	Type L (Light)	Gabion Or Loose
Public Works Approval	300 (136.1)	By V.S. Design ACOE Method	Type M (Medium)	Loose
Public Works Approval	750 (340.2)	By V.S. Design ACOE Method	Type H (Heavy)	Loose
Public Works Approval	2,500 (1,134)	By V.S. Design ACOE Method	Type VH (Very Heavy)	Loose

\*\* (Note: For Use in twelve (12) inch (0.305m) high or smaller gabions.

Grouted rip-rap shall be hand placed in a mortar bed to a minimum of 1/3 the diameter or of 3” thick, whichever greater, of type “s” mortar. Rip-rap shall not be placed deeper than 1/2 the thickness of the grout bed. Voids in the rip-rap shall be completely filled with mortar for the full thickness of the rip-rap. After the grout is placed, the surface of the rip-rap shall be swept with a stiff broom. The finished surface of the rip-rap shall not vary more than three inches from the design grade. Riprap stones shall conform to the following:

**MINIMUM REQUIREMENTS FOR GROUTED RIP-RAP**

Water Velocity Fps (m/s)	Stone Volume ft <sup>3</sup> (m <sup>3</sup> ) Ex. 1/3 Stone + 2/3 Mortar = 1 Unit Grouted Rip-Rap		*Minimum Dimension in (mm)
	Min.	Max.	
0-5 (0-1.5)	1/3 (0.009)	1 (0.028)	3 (76.2)
5-10 (1.5-3.0)	1 (0.28)	2 (0.57)	6 (152.4)

\* - Minimum size in the least dimension.

(D) *Open channels.*

- (1) *General criteria.* Except as modified in this division, open channels shall be designed for the major storm event (1% chance storm) with additional analysis showing the effects of the initial (10% chance) storm. Whenever practical, channels should be designed to avoid flows at or near supercritical depth. Channel capacities should be computed using sound engineering practices, if the City determines potential backwater conditions exist a more extensive analysis (HEC II, HEC-RAS) will be required. No channel shall have a depth less than critical depth plus freeboard.
- (2) *Hydraulics.* The channel cross section may be of the type most suited to the location. The drainage report and design hydraulics of flow in channels shall include analysis of the hydraulics indicating the following parameters for existing and proposed channels and drainage ways:
  - (a) Flow cross section geometry for each different configuration of channel shape.
  - (b) Flow cross sectional area.
  - (c) Wetted perimeter.

- (d) Hydraulic radius.
  - (e) Manning's roughness coefficient (n).
  - (f) Flow velocity.
  - (g) The maximum capacity of the channel, including freeboard requirements.
  - (h) Design discharge.
  - (i) Bed slope.
  - (j) Froude number.
  - (k) Freeboard requirement based on 1% chance event. (minimum 12 inches) (0.305 m)
  - (l) Flow type (subcritical, critical, or supercritical)
- (3) *Erosion.* All channels shall be designed with the proper and adequate erosion control features.
- (4) *Water surface profile.* A water surface profile for the major storm runoff shall be computed for all channels and clearly shown on final drawings submitted for approval. Computations of the water surface profile shall utilize standard backwater methods, taking into consideration all losses due to velocity changes, drops, bridge and culvert openings, and other obstructions. Computations shall be submitted with the final design plan. The energy gradient line should also be computed and be shown on the final drawings. The engineer shall be responsible for obtaining FEMA approval of Flood Insurance Study (F.I.S.) flood hazard zone changes and new/revised flood zone maps as part of the project development.
- (5) *Unlined Channels.* Unlined channels shall be classified as channels whose slope maintains flows with a Froude number of 0.8 or less. Drops may be used to maintain these criteria. All channels will be evaluated on a case-by-case basis considering, depth, side slopes, lining, velocity, safety, etc.
- (a) *Side slopes.* Side slopes shall be as flat as practical. Side slopes of 4:1 (horizontal to vertical) shall be considered a normal Maximum. Any side slope steeper than this will require written approval from the Public Works Director.
  - (b) *Flow Depth.* The maximum design depth for the major storm

runoff shall be 4.0 feet (1.219M) in open channels, unless otherwise authorized by the Public Works Director.

- (c) *Design velocity.* A maximum velocity for the major storm runoff needs to recognize the scour potential of the soil-vegetative complex. Average velocities need to be determined by mixed flow analysis using HEC-RAS which account for drops, expansions, contractions and other structural controls. Velocities need to be kept sufficiently low to prevent excessive erosion in the channel. The following velocities are recommended as maximums for major storm runoff flows:

**Table 32-105.5.C**

Cover	Maximum Velocity (fps) (mps)	
	Clay (Erosion Resistant Soil)	Sandy (Easily Eroded Soil)
No cover, dirt lined	4.0 (1.219)	2.5 (0.7620)
*Buffalo grass, bluegrass, smooth brome, blue gramma, native grass mix	7.0 (2.134)	5.0 (1.524)
*Lespedeza, lovergrass, kudzu, alfalfa, crabgrass	4.5 (1.372)	3.0 (0.914)

\*Grass cover assumed to be a good stand and well maintained.

- (6) *Lined Channels.* Lined channels are defined as those exhibiting characteristics which would require lining of the channel to ensure structure stability, to achieve the desired design life of the channel, and to protect areas adjacent to the structure. Contributing factors in the analysis to channel lining requirements include bed slope, flow rate, soil type and stability, and any flow conditions that cause velocity changes. Generally, in most soil conditions, channels exhibiting hydraulic characteristics which result in a Froude number of 0.8 or greater during the 10% chance or 1% chance storm will require stabilization in the form of a lining. All channels will be evaluated on a case-by-case basis considering, depth, side slopes, lining, velocity, safety, etc.

- (a) *Side slopes.* Side slopes of a channel shall be those best suited to the terrain and location. Maximum channel slopes with minimal slope protection and/or stabilization, as in Table 32-105.5.c shall be no steeper than 2:1 (Horizontal :Vertical).

- (b) *Depth of flow.* The depth of flow shall be kept to a minimum, considering velocities involved and land areas needed for drainage easements.

- (c) *Lining materials.* Lining materials shall be composed of one of the following:



- (1) Concrete of sufficient strength and thickness to support all design loads, including maintenance equipment. Roughening of concrete surfaces is encouraged.

Roughening may be accomplished by use of darbies, exposed aggregate, or other suitable methods approved by the Public Works Director.

- (2) Asphalt of sufficient strength, including base materials, to support all anticipated design loads, including maintenance equipment. Asphalt linings shall be of a mix design which will resist damage due to erosion and lack of vehicular traffic for the design life of the lining which shall be 20 years.
- (3) Riprap, set in concrete or mortar, shall have the rock size and weight sufficient to resist displacement of the rock by the energy present in the flow of the major storm event. Riprap may be stabilized by grouting, can be set in concrete, or may be wire tied. Standard gabions may be used to stabilize rock under some conditions.
- (4) Other types of linings such as wood, metal, tile, wire-tied rip rap, reno mattress, brick, fibermesh concrete, or other materials may be used when approved by the Public Works Director.

- (d) *Freeboard.* The design of channels at supercritical stages shall be taken into account; requirements for freeboard to provide a splash and hydraulic jump phenomenon. For conditions of uniform flow, the minimum lined elevation shall include freeboard above the flow surface of the major storm and shall be calculated using the following equation:

[Sub-Critical Flow]

$$\text{Freeboard (in feet)} = d/4 + 0.025 * (v) * (d)^{1/3}$$

Where:

d = Depth of flow (feet)

v = Velocity of flow (ft./sec.)

$$\text{Freeboard (in meters)} \\ d/4 + 0.025 * (v) * (d)^{1/3}$$

Where:

d = Depth of flow (meters)

v = Velocity of flow (m/s)

For conditions where the total energy content of the flow must be considered, such as bends, drops, abrupt changes in grade or area, convergence of flows, obstructions within the channel, and other conditions which may produce a hydraulic jump, the minimum freeboard above the flow surface of the major storm runoff shall be calculated using the following equation:

[Super Critical and Critical Flow]

$$\text{Freeboard (in feet)} = 0.5 + \frac{v^2}{2 \cdot g}$$

$$\text{Freeboard (in meters)} = 0.152 + \frac{v^2}{2 \cdot g}$$

Where:

v = Velocity of flow (m/s)

g = Gravity constant = 9.81 m/s<sup>2</sup>

Where:

v = Velocity of flow (ft./sec.)

g = Gravity constant 32.3 ft./sec.<sup>2</sup>

Minimum freeboard under bridges shall be two feet (0.610)

(7) Walls adjacent to open channels shall be constructed to an elevation that is a minimum of six inches (6") (0.152m) above the finish lot grade at the time of roadway construction.

(E) *Storm Drain Lift Stations.* The use of storm drain lift stations is strongly discouraged and will be considered only in cases involving extenuating circumstances.

All lift stations will be designed to handle twice the 100 year routed peak flow rate and have a detention pond capable of removing silt, debris and, floatable material before entering the lift station entrance works. Under no circumstance shall a channel feed directly into a lift station.

At a minimum, all lift stations must have an exerciser in the control panel and be equipped with a Supervisory Control and Data Acquisition (SCADA) system

compatible with the existing City system. The pumps will be driven by a three-phase power system and have a redundant power source such as another electrical grid or an automated generator capable of driving all the pumps simultaneously.

(Ord. No. 949, § 3.1E, 9-8-87; Ord. No. 1224, § 1, 3-18-91)

**Sec. 32-106. Retention/Detention pond design.**

- (A) The use of on-site detention/retention is required for the purpose of limiting the initial ten (10% chance) and major one (1%) chance storm runoff rates to historical levels. The type of design for each facility is subject to approval by the Public Works Director.
- (B) Detention/Retention pond facilities should be designed using a storage outflow relationship for the facility and a flood hydrograph routing procedure. For drainage basins smaller than 1 acre (.4047 ha), only retention ponds shall be used, detention or retention ponds may be used only for developments larger than 1 acre (.4047 ha).
- (C) For drainage basins larger than one (3) acres (.4047 ha), a flood hydrograph routing method will be required.
- (D) Off-site runoff entering the development may occur in the drainage basin, and if this is the case, the analysis for the detention facility must take the flows into account. Off-site runoff should be analyzed as outlined herein. Off-site flows may be routed around the detention facility. However, entrance and exit points of storm runoff shall not be altered nor shall the post development peak flow exceed that historic peak flow for both 1% and 10% chance rain events.
- (E) Those developments immediately adjacent to specific major drainage ways may have the detention requirements waived, subject to approval by the Public Works Director. These areas must be thoroughly analyzed to show that no additional hazards will be created downstream and that downstream facilities (channels and/or detention/retention areas) can safely handle the increased flow rates or volumes. The City's Storm Water Management Policy plan must be adhered to as well. This document requires the controlling and maintaining of major arroyos without damaging or affecting habitat, recreation, or open space values of these arroyos.
- (F) For any detention/retention facility design, a soils report shall be included. This report shall include but not be limited to soil boring logs, water table elevations and soil classifications. Sufficient and representative soil borings and tests shall be required to illustrate suitability for intended purpose and percolation characteristics.

- (G) Compliance with the City’s Storm Water Management Policy Plan must be completed as a supplement to this design standard.

(Ord. No. 949, § 3.1F, 9-8-87; Ord. No. 1224, § 1, 3-18-91)

**Sec. 32-107. On lot ponding; minimum pad elevations.**

- (A) One common manner in which post development runoff is controlled at or below pre-developed conditions is by way of on-lot ponding. When this approach is used there shall be restrictive covenants filed on record at Dona Ana County to convey drainage requirements from seller to purchaser. When on-lot ponds are proposed a ponding icon shall be shown on all plats to indicate that the lot requires a pond and is the responsibility of the property owner to maintain. When on-lot ponding is proposed all lots shall have on-lot ponds and the percent credit shall be as follows:

<b>Lot Size</b>				<b>% Credit</b>
ft <sup>2</sup>	ac	(m <sup>2</sup> )	(ha)	
0-8,300	0-0.1905	(0-771.1)	0-0.077	10
8,300-10,890	.1906-.250	(771.2-1011.7)	.077-.101	40
10,891-21,780	0.25-0.500	(1011.7-2023)	0.101-0.202	70
21,780-43,560	0.500-1.00	(2023-4047)	0.202-0.405	85
43,560-	1.00 +	(4047 +)	0.405	100

Required ponding volume ≥ Credit \* volume of lot ponds + volume of regional pond.

Example: A 10 lot subdivision, with 0.2 acre lots, is determined to require 5, 000 cubic feet of on-site volume. The engineer decides to place 600 cubic foot ponds on each lot. The regional pond will be required to hold 2,600 cubic feet.

$$5,000 - ((10 \times 600) \times 0.40) = 2,600 \text{ cubic feet required in regional pond.}$$

- (B) There will not be a minimum pad elevation for houses on lots in the five-mile ETZ. However, the grading plan must reflect pad elevations in relationship to the center of the street and have been stamped by a professional engineer licensed in the State of New Mexico which would certify the drainage plan as workable.
- (C) An area of two feet (0.609m) out from the perimeter of the house must be a maximum 2% slope away from the pad of the structure.
- (D) All required ponding must be constructed at time of initial grading and must not be deferred until home construction is started and must not be altered during home construction without an engineered solution.

- (E) Many different ponding configurations can serve the foundation of detaining/retaining storm water runoff. However, the City will limit the types of ponding areas that can be used and has further described them as follows:

The type and design for each facility is subject to approval by the Public Works Director and Facilities Director for Type C pond. Three specific types of storm water ponding areas will be permitted. The ownership, operation and maintenance responsibilities affect the design of the ponding area.

Type “A” – Private

Type “B” – City (Drainage Facility)

Type “C” – City (Park/Dual Use Facility)

The following parameters shall be used to guide the design of the three types of ponding facilities:

Element	Type A – Private	Type B – Drainage Facility	Type C – Park / Dual use
Operation and Maintenance	Private	City Streets Section	City Parks Section
Size	Any	One Acre Minimum (.405 ha)	2.5 Acres Min. (1.01 ha) (or as directed by the minimum park size)
Shape	Any	Rectangular Preferred	Any
Depth <sup>+</sup>	18” Minimum (0.457 m) 4 Feet Maximum (1.21 m) <sup>+</sup>	Same as Type “A”	Same as Type “A”
Capacity	As needed to hold Generated Runoff	As needed to hold generated runoff plus an additional equivalent volume to provide a regional benefit	Same as Type “A”
Side Slopes*	> 4:1 Erosion control measures 2:1-3:1 Stepped or grouted rock (slope stabilization)	8:1 with natural slopes As steep as 4:1 when erosion control and access ramp are provided	Same as “B”
Access	Optional	Must have improved access road with 8:1 maximum slope	Same as “B”
Outlet	Must lead to drainage way, right of way (approval needed), or drainage easement	Same as Type “A”	Same as Type “A”
Storage time	Must drain or percolate within 24 hours	Same as Type “A”	Same as Type “A”
Landscape (when landscaped)	To be approved by the City Landscape Architect (see CLC Storm Water Management Policy Plan) <sup>♣</sup>	Low maintenance perimeter buffer to be approved by Public Works Dept.	To be approved by the City Landscape Architect and Parks Department
Fencing/Railing	Optional – Unless hazard exists to those using public property	Required – Maintenance access gate also required	Same as Type “A”

Table Continued				
Park Credits	Fee	Case-by case	None	Same as Type "A"

\* Sandy soil may require erosion protection with slopes flatter than 6:1, slopes steeper than 2:1 are not allowable.

+ Ponds deeper than 4 feet will be considered, when additional safety measures are taken.

♣ Non-residential only.

(Ord. No. 949, § 3.1G, 9-8-87)

**Sec. 32-108. Drainage system operation and maintenance.**

(A) The actual effectiveness of any storm drainage system compared to that determined through modeling and other engineering computation procedures may differ greatly. The intake capacity of a storm drain inlet can be reduced by more than 75 percent due to debris accumulation. Trash collecting on a pier of a bridge over a flood control channel may actually direct water out of the channel although the discharge is well below the channel design capacity. Sand and silt accumulations within a storm sewer may completely block the line. Pump stations that have not been regularly exercised may not operate when called upon.

(B) In order to increase system efficiency and improve the city drainage systems, the following maintenance guidelines should be adopted by the city and operators of private drainage systems:

Facility	Maintenance	Inspection
Channels	Monthly June—October	Semiannual
Pump stations	Monthly June—October	Semiannual
Detention facilities	As necessary monthly June—October	After any major storm (one inch or greater)
Storm sewer systems	Annual	Biannual
Storm sewer inlets	After rainfall events or biweekly during rainy periods	Semiannual

(C) Proper operations and maintenance of storm drainage and flood control facilities includes both cleaning and minor repair to the facilities as well as completely rebuilding some facilities which have, through weathering or lack of maintenance, been rendered useless or present a threat to public safety.

(Ord. No. 949, § 3.1H, 9-8-87; Ord. No. 1224, § 1, 3-18-91)

**Sec. 32-109. National Pollutant Discharge Elimination System (NPDES)**

(A) Persons obtaining construction permits clearing over 1 acre of ground should be aware that they are subject to the federal Environmental Protection Agency (EPA) Construction General Permit, State of New Mexico Environment Department Regulations, and City of Las Cruces Ordinance 2146 regarding pollution of storm water. Visit the City’s website for the latest updates and assistance.

[http://www.las-cruces.org/public\\_works/engineering\\_services/stormwater.asp](http://www.las-cruces.org/public_works/engineering_services/stormwater.asp)

**Secs. 32-109--32-135. Reserved.**

### **DIVISION 3.**

#### **FENCES AND WALLS AND RETAINING WALLS**

**Sec. 32-136. Scope of division.**

Construction of all fences, walls or retaining walls within the city shall require an approved building permit issued by the city, and shall conform to the minimum design standards as specified within this division.

(Ord. No. 949, § 3.2A, 9-8-87; Ord. No. 1224, § 1, 3-18-91; Ord. No. 2131, § I, 9-7-04)

**Sec. 32-137. Definitions.**

The following words, terms and phrases, when used in this division, shall have the meanings ascribed to them in this section, except where the context clearly indicates a different meaning:

*Decorative wall* means any wall used for landscaping purposes not more than 24 inches in height, 12 inches wide, and not located on property lines.

*Fence* means an artificially constructed barrier of posts, wire, wood, steel, cable or similar material erected to enclose or screen areas of land.

*Retaining wall* means an artificially constructed structure that retains 4.0 feet of grade differential or a surcharge load.

*Wall* means an artificially constructed barrier of solid material such as brick, block, rock, or concrete, erected to enclose or screen areas of land.

(Ord. No. 949, § 3.2A, 9-8-87; Ord. No. 2131, § I, 9-7-04)

**Cross References:** Definitions generally, § 1-2.

**Secs. 32-138--32-142. Reserved.**

**Editors Note:** Ord. No. 2131, § I, adopted Sept. 7, 2004, repealed sections 32-138--32-142, in their entirety. Former sections 32-138--32-142 pertained to the application procedure, retention and validity of approved plans, expiration of permits and submittal requirements, and derived from Ord. No. 949, § 3.2B--F, adopted Sept. 8, 1987; Ord. No. 1929, §§ I, II, adopted Aug. 5, 2002.

**Sec. 32-143. Wall design requirements.**

In addition to the following wall design requirements, (1)--(6) refer also to the rock/mortar retaining walls diagram and construction notes found at the end of this section.

- (1) Under this division, the permittee shall be responsible for the location of all property lines affected by a proposed wall and shall be responsible for the placement of footings and walls with respect to property boundaries.

- (2) Subgrade for walls shall be compacted to 90 percent of modified proctor as determined by ASTM standard D1557.
- (3) Concrete for footings shall be transit mix and shall attain a minimum strength of 2,500 psi in 28 days. The bottom of the footings shall be located a minimum 12 inches in thickness below the finish grade of soil. Hand mix concrete will only be allowed in footings having a total lineal footage of 25 feet or less within the entire project.
- (4) Reinforcing steel for concrete footings shall be two number 4 continuous deformed bars conforming to ASTM standard A617 and shall be grade 40.
- (5) Mortar shall attain a minimum of 1,200 psi in 28 days with a suggested mix in the ratio of one part Portland cement by volume with over one-fourth to one-half parts of hydrated lime or lime putty by volume, and the aggregate shall be not less than two and one-fourth; and not more than three times the sum of the volumes of the cement and lime used; or one-half by volume of cement, one part by volume of type II masonry cement, and the aggregate shall not be less than two and one-fourth and not more than three times the sum of the volume of the cement used. Minimum thickness of rock walls shall be 16 inches, except decorative walls.
- (6) For subdivision development, walls are not required to be built at the time of roadway construction unless under the following circumstances:
  - a. Adjacent to dedicated right-of-way.
  - b. Abutting an existing wall or a retaining wall for the purposes of mitigating erosional damage to adjacent development, where the existing wall or retaining wall's height is less than 3.0 feet above the proposed grade. Construction of the wall or retaining wall shall be a minimum 4.0 feet in height, measured from the proposed grade.

(Ord. No. 949, § 3.2G, 9-8-87; Ord. No. 2131, § I, 9-7-04)



# Rock/Mortar Retaining Walls

(Retain up to 4 ft with additional garden walls up to 6 ft)

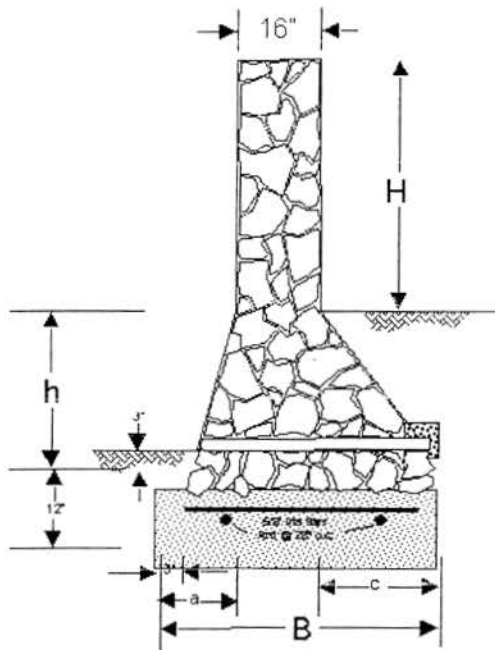

Dimensions				
H	h	B	a	c
All Dimensions are in inches				
24 to 72	0-20	22	0	0
	21-27	25	3	0
	28-39	25	3	0
	40-61	47	4	21

## Conditions

- Backfill shall be flat or slope away from wall
- No surcharge loads allowed within  $3 \times h$  (ft) from wall
- No vertical/lateral loads can be added to wall
- Backfill must not be clay or clay like materials
- Backfill and sub-grade must be granular and well drained
- A 12" x 12" continuous gravel drain (3/4" material) is required.
- 3" diameter schedule 10 PVC weep holes shall be provided at  $2 \times h$  (in ft) max when walls are higher than 20".
- Weep hole shall be covered with a fine mesh located 3" above the bottom of the gravel drain.
- Walls must only be used in stand alone conditions, not in parallel or in series.
- City reserves the right to stop work if any deviation is noted

## Materials

- Concrete for footings – 2,500 psi (28 days) w/ 1-3/4" MSA and max 4" slump
- Rebar – Grade 40 min.
- Mortar – either lime or type s mortar cement.

Mortar proportions:

Portland Cement (low alkali) 1 part

Hydrated lime (type s) 1/2 part

Clean washed mortar sand (imported) 4 1/2 parts.

## Methods

- Soil under footing to be scarified (8") and compacted to 95% of modified proctor and within 2% of optimum moisture content and maintained in such condition until footing is poured
- Soil used for backfill around wall must be placed with the same conditions above unless the soil has more than 35% finer than a #200 sieve in which case 90% compaction will be allowed.
- Forms may be required if the soil will not hold a vertical face for pouring the footings.
- Rebar shall be placed with a minimum of 3" clearance from the ground and approved chairs or pre-cast risers must be used.
- The first course of rock must be imbedded in the footings by at least 6"
- Wall must be solid with no voids in the center with large interlocking stones which typically interlock and overlap both horizontally and vertically. No debris will be permitted in the wall, all voids must be filled with quality mortar.
- Mortar joints must not recess more than 1/2 inch from the face of the wall

**Sec. 32-144. Retaining wall design requirements.**

- (a) Under this division, the permittee shall be responsible for the location of property lines affected by a proposed retaining wall and shall be responsible for the placement of footings and walls with respect to property boundaries.
- (b) Subgrade for retaining walls shall be compacted to 95 percent of modified proctor as determined by ASTM standard D1557.
- (c) Concrete for footings shall be transit mix and shall attain a minimum strength of 2,500 psi in 28 days. The bottom of the footings shall be located a minimum 12 inches in thickness below the finish grade of soil. Hand mix concrete will only be allowed in special circumstances as approved by the city.
- (d) Reinforcing steel for concrete footings shall be deformed bars conforming to ASTM standard A617 and shall be grade 40 and per the approved engineer's design.
- (e) Mortar shall attain a minimum of 1,200 psi in 28 days with a suggested mix in the ratio of one part Portland cement by volume with over one-fourth to one-half parts of hydrated lime or lime putty by volume, and the aggregate shall be not less than two and one-fourth and not more than three times the sum of the volumes of the cement and lime used; or one-half by volume of cement, one part by volume of type II masonry cement, and the aggregate shall not be less than two and one-quarter and not more than three times the sum of the volume of the cement used.
- (f) Portland cement for mortar shall conform to ASTM standard C150 and shall be type I or type II.
- (g) Backfill material to be placed adjacent to the retaining walls shall be a granular soil with compaction requirements as per the engineer's design. Expansive type soils are prohibited as backfill materials.
- (h) Developers, subdividers, or builders shall submit retaining wall design drawings and specifications including design calculations for each wall to be constructed; or various options of the type and style of retaining walls may be used and receive approval through the subdivision construction drawing approval process for the respective subdivision as provided in article X of chapter 37.
- (i) For subdivision development, walls are not required to be built at the time of roadway construction unless under the following circumstances:
  - (1) Retaining embankment in dedicated right-of-way.
  - (2) Abutting an existing wall or a retaining wall for the purposes of mitigating erosional damage to adjacent development; where the existing wall or retaining wall's height is less than 3.0 feet above the proposed grade.

Construction of the wall or retaining wall shall be a minimum 4.0 feet in height, measured from the proposed grade.  
(Ord. No. 949, § 3.2H, 9-8-87; Ord. No. 2131, § I, 9-7-04)

**Secs. 32-145--32-175. Reserved.**

**Editors Note:** Ord. No. 2131, § I, Sept. 7, 2004, repealed sections 32-145, 32-146, in their entirety. Former sections 32-145, 32-146, pertained to inspections and certificate of compliance, and derived from Ord. No. 949, §§ 3.2I, 3.2J, adopted Sept. 8, 1987; Ord. No. 1929, §§ I, II, adopted Aug. 5, 2002.

**DIVISION 4.**

**SOILS TESTING**

**Sec. 32-176. Specific standards.**

(a) *Utilities.* Under this division, construction permits shall be applied for and issued to the contractor responsible for the actual placement of the utility in order that the city will be properly informed of the exact dates and times of construction activity. Test requirements shall include the following:

- (1) Trenching.
  - a. Pipe bedding. One field density per 150 linear feet (lf).
  - b. Backfill. One field density per 150 linear feet (lf) per two feet depth of backfill (each side).
- (2) Services. Service stubouts: One field density per every third service (not per lift).
- (3) Manholes.
  - a. Soil density tests.
  - b. One field density per footing to be poured.
  - c. One field density per 24 inches of backfill around the manhole.
  - d. Materials tests.
  - e. One mortar test per manhole per day.
  - f. One concrete test per manhole per day.
- (4) Miscellaneous concrete structures.

- a. One field density per structure.
- b. One concrete test per structure.

Densities are per ASTM D-2922, D-1556, or D-2167.

(b) *Moisture density relationship of soils.* Moisture-density relationship of soils shall meet AASHTO-T180 or ASTM D-1557 as required by changes in materials.

(c) *Street construction test requirements.* Test requirements for street construction shall be as follows:

(1) *Field densities.*

- a. *Subgrade.* One field density per 150 lf per eight-inch lift.
- b. *Curb and gutter.* One field density per 125 lf or per placement.
- c. *Sidewalk.* One field density per 150 lf or per placement.
- d. *Base course.* One field density per 125 lf.
- e. *Miscellaneous backfill.* One field density per eight-inch lift or as directed by the chief engineer.

(2) *Gradations.*

- a. Gradations shall include fractured faces, liquid limit and plasticity index.
- b. Base course. One per 300 lf or per project. Additional tests may be required by the chief engineer.

(3) *Modified proctors.* As required by change in materials.

(4) *L.A. wear and soundness.* One test per source per six months.

(5) *Special notes.*

- a. Moisture limits on field density  $\pm$  two percent.
- b. High volume change soils. Thirty-five percent or more of the material passing the no. 200 sieve shall be compacted to 90 percent of modified proctor.
- c. Compaction effort. Ninety-five percent for in situ soils.

- d. Types of material allowed for backfill shall meet the following specifications unless otherwise authorized by the public works director:
  - 1. Backfill material shall be free of any organic or deleterious substances and shall not contain cobbles or lumps over four inches in greatest dimension.
  - 2. Backfill materials shall contain not more than 60 percent by weight of material larger than a no. 4 sieve and in addition shall be uniformly graded with not more than 40 percent passing a no. 40 sieve nor more than 15 percent passing a no. 200 sieve. The material shall show low shrinkage or swelling and it shall be nonplastic.

(d) *Hot mix asphaltic concrete (HMAC).*

- (1) One gradation, extraction and briquette and two field densities per block (350 lf) or as required by community development department personnel.
- (2) Establishment of a rolling pattern is recommended at time of job startup.
- (3) Testing of materials from hot bins and sand equivalence testing shall be accomplished at job startup in conformance with the city standard specifications for roadway construction or as outlined by the public works director.

(e) *Concrete.* One slump test, set of cylinders (three minimum), and air content determination, if required, per 50 cubic yards placed or fraction thereof, per day.

(f) *Grout and mortar.* Tests for mortar and grout used in construction of manholes, rockwalls, and rock retaining walls shall be as determined by the inspector.

(g) *Concrete paving.* One slump test, one air content determination, one set of cylinders (three minimum per set) and one set of beams (three minimum per set), per 150 cubic yards placed or fraction thereof, per day.

(Ord. No. 949, § 3.3A, 9-8-87; Ord. No. 1224, § 1, 3-18-91; Ord. No. 1929, §§ I, II, 8-5-02)

**Secs. 32-177--32-235. Reserved.**

## DIVISION 5.

### DETAILS\*

---

\* **Editors Note:** Ord. No. 1789, § II, adopted April 3, 2000, repealed division 5, sections 32-206, 32-207, in its entirety and renumbered division 6, section 32-236, as new division 5. Former division 5 pertained to erosion control and derived from Ord. No. 949, §§ 3.4A, B, adopted Sept. 8, 1987; Ord. No. 1048, adopted Jan. 17, 1989; and Ord. No. 1224, § 1, adopted March 18, 1991.

---

#### Sec. 32-236. Details.

The details referred to in this article include the following:

Title	No.
Vehicle access ramp	D-1
Typical channel lining	D-2
Typical toe-down detail (end of channel)	D-3
Access road detail	D-4
Curb inlet plan (modified)	D-5
Curb inlet section A-A (modified)	D-6
Curb inlet elevation (modified)	D-7
Curb inlet details (min. standard)	D-8
Drop inlet details (min. standard)	D-9
Standard manhole section	D-10
Manhole details	D-11
Typical storm drain installation	D-12
100-year rainfall patterns	D-23

(Ord. No. 949, § 3.5, 9-8-87)

**Secs. 32-237--32-265. Reserved.**

## ARTICLE IV.

### DEVELOPMENT STANDARDS FOR LANDSCAPING

#### Sec. 32-266. Scope of article.

(a) The city wishes to promote and preserve visually attractive and pleasing surroundings, reduce erosion and runoff, and improve the quality of the environment. The city desires to have development in an attractive and high quality manner. Therefore, landscaping shall be provided and maintained as set forth in this article.

(b) The style of landscape is not described; however, indigenous or drought tolerant plants are recommended.

(c) For purposes of this article, the term "site" will be defined as the lot included within the application for which the permit is sought and upon which the landscape obligations of this article are imposed.

(d) It is important to note that the guidelines in this article are minimum acceptable standards.

(e) The standards in this article shall apply to public and private property in the following circumstances:

- (1) All new construction within the M-2, M-1, C-2, C-1, R-4, R-3, and R-2 zoning districts shall require landscaping. The parking area will determine the amount of landscaping required for the site. A minimum area equal to 15 percent of the total parking area shall be landscaped. For the purposes of this article, the parking area includes the entire tract of land except for the building pad and fenced-in storage area. Properties that are occupied by single-family residences, townhouses, or duplexes located on individual lots are exempt from these requirements. Up to one-third of the required landscaping may be located in the public right-of-way.
- (2) Additions or structural modification to existing buildings with a value of \$25,000.00 or over and all new parking lots being paved within the M-2, M-1, C-2, C-1, R-4, R-3, and R-2 zoning districts shall require landscaping. The parking area will determine the amount of landscaping required for the site. A minimum area equal to 15 percent of the total parking area shall be landscaped. For the purposes of this article, the parking area includes the entire tract of land except for the building pad and fenced-in storage area. Also, all areas that are currently being used as parking that are unpaved and are being paved shall require an area that is equal to not less than 15 percent of the site's parking area, as defined in this subsection, to be landscaped. Properties that are occupied by single-family residences, townhouses, or duplexes located on individual lots are

exempt from this requirement. Up to two-thirds of the required landscaping may be located in the public right-of-way. Any building to be structurally modified, but not enlarged, that does not have area to landscape due to parking and other requirements may be exempted from these requirements administratively after review during the permitting process shows an inability to comply.

- (3) All uses requiring special use permits, as defined by chapter 38, shall require an area that is equal to not less than 15 percent of the site's parking area, as defined in this subsection, to be landscaped. Up to one-third of the required landscaping may be located in the public right-of-way.
- (4) For the protection and enhancement of our native environment, in calculating the required area to be landscaped the owner may include naturalized vegetation on the site which is undisturbed by clearing of the site, provided that tumbleweed, snakeweed, and bursage will not be considered naturalized vegetation for this purpose. Only areas of undisturbed naturalized vegetation may also be exempted from installation of an irrigation system if the owner so desires; however, 15 percent of the parking area, as defined by this subsection, must be reserved for landscaping. This area must be shown in the first phase of development.
- (5) All auto sales lots, mobile home sales lots and other vehicle sales lots shall provide ten percent of the parking area, as defined in this subsection, to be landscaped.

(Ord. No. 978, §§ 4.1, 4.1.A, 6-20-88; Ord. No. 1095, §§ 4.1, 4.1.A, 9-18-89; Ord. No. 1221, 2-4-91)

### **Sec. 32-267. Definitions.**

(a) The following words, terms and phrases, when used in this article, shall have the meanings ascribed to them in this section, except where the context clearly indicates a different meaning:

*Ground cover* means grass, low shrubs or flowers, but does not include asphalt, concrete or soil which is exposed and untreated located throughout the required landscaped area. One hundred square feet of ground cover or ten one-gallon size plants shall be provided for every 1,000 square feet of required landscaped area. Gravel and decorative stone shall be considered an additional ground cover if used with the required plant material specified in this article.

*Irrigation system* consists of an underground system, automatic or manual, that includes a reduced principle backflow preventor, pipes, valves, and heads and that shall be of an adequate size to properly irrigate the proposed planting.



*Landscape* means trees, shrubs, and ground covers, all of which are defined in this section. Also included shall be an irrigation system which is defined in this section.

*Shrubs* means five-gallon size, to follow nurseryman standards, which are approximately one foot in height and one foot in width at the time of planting located throughout the required landscaped area. A minimum of 20 live shrubs shall be provided for every 1,000 square feet of required landscaped area.

*Trees* means deciduous or conifer trees having a two-inch to 2 1/4-inch caliper at the time of planting located throughout the required landscaped area. A multitrunk tree shall have no less than three one-inch caliper trunks. A minimum of one live tree shall be provided for every 1,000 square feet of required landscaped area.

(b) Substitution of plant materials may be made according to the following ratios:

(1) Every one two-inch tree required equals ten five-gallon shrubs.

(2) Every one five-gallon shrub required equals five one-gallon shrubs.

(3) Every one two-inch tree required equals 30 one-gallon shrubs.

(Ord. No. 978, § 4.1.B, 6-20-88)

**Cross References:** Definitions generally, § 1-2.

**Sec. 32-268. Locational criteria.**

(a) Of the total area required to be landscaped under this chapter, one-half shall be located within the front portion of the property. For purposes of this article, the front of the property shall be defined as the area between the street curb and the principal structure (see figure 1).

(b) Where buildings occupy corner lots, double fronting lots or triple fronting lots, the owner shall locate a minimum of one-fourth of the required landscape percentage within each front.

(c) All new parking lots with more than 100 spaces that are required to landscape shall locate some of the plant material in the parking lot for shade and visual relief.

(Ord. No. 978, § 4.2, 6-20-88)

**Sec. 32-269. City-owned property or property dedicated to city.**

(a) The city has adopted landscape themes for medians that shall act as a guide for development of medians.

(b) All owners who dedicate land to the city and who choose to include landscape improvements in addition to the mandatory requirement, such as medians,

subdivision entrances, drainageways and rights-of-way, shall submit plans for planting and irrigation for the approval of the community development and facilities departments, affected utilities and the state highway department, if appropriate, prior to construction. Any such dedication of land shall be in addition to the requirements for dedication of park land or fees in lieu thereof as stated in chapter 37.

(c) Design guidelines for properties that are to be dedicated to the city shall be as follows:

- (1) Grassed areas shall have a maximum design slope of 5:1, that is, five feet horizontal distance for every one foot vertical. Mounded ground cover areas shall have a maximum design slope of 3:1, that is, three feet horizontal distance for every one foot vertical.
- (2) Pedestrian crossing areas shall be surfaced with a hard paving suitable for foot and wheelchair traffic.
- (3) An irrigation system with an automatic controller shall be installed.

(d) All medians shall contain a minimum two-inch water stubout. Those medians in a series under one development shall contain one two-inch stubout and one two-inch conduit between medians which is suitable for electricity and water. The conduit shall be a minimum of two-inch schedule 40 PVC and shall be placed a minimum of 24 inches underground.

(e) All drainage, retention and detention areas shall be buffered in accordance with table 1.

(f) If a resident landscapes any property that is dedicated to the city, such resident is responsible for maintenance of that area in accordance with sections 32-273 and 32-274 until a written agreement is made to the contrary with the city. (Ord. No. 978, § 4.3, 6-20-88; Ord. No. 1224, § 1, 3-18-91; Ord. No. 1929, §§ I, II, 8-5-02)

### **Sec. 32-270. Buffers and screens.**

(a) All owners of property required to be landscaped under section 32-266 or otherwise under chapter 38 shall buffer their property lines in accordance with table 1. The type of screening required is determined by the zoning classification of the property.

---

(b) The installation of the screening is the responsibility of the applicant prior to issuance of a building permit.

Subject Property (Building Permittee)	Adjacent Property Zoning District						
	R-1, R-2, R-3	R-4	O-1	C-1	C-2	M-1	M-2
R-1, R-2, R-3	C						
R-4	C	C					
O-1	B	B	C				
C-1	B	B	B				
M-1	A	A	A	A	B		
M-2 detention, retention, drainage facilities	A	A	A	A	A	C	

TABLE 1

Type A = Opaque screen

Type B = Semiopaque screen

Type C = Broken screen

Definitions of these types follow in subsection (c) of this section.

- (c) The types of buffers or screens described in table 1 are as follows:
- (1) *Opaque screen, type A.* A type A opaque screen is a screen that is opaque from the ground to the height of at least six feet with intermittent visual opening from the opaque portion to a height of at least 20 feet. An opaque screen is intended to exclude all visual contact between uses and to create a strong impression of spacial separation. The opaque screen may be a combination wall, fence, landscaped earth berm, planted and existing vegetation. All landscaping in the buffer area must have an irrigation system. Trees and shrubs shall be located so that their outermost limbs touch at the time of maturity. Suggested planting patterns that will achieve this standard are included below.
  - (2) *Semiopaque screen, type B.* A type B semiopaque screen is a screen that is opaque from the ground to a height of three feet, with intermittent visual openings from above the opaque portion to a height of at least 20 feet. The semiopaque screen is intended to partially block visual contact between uses and to create a strong impression of the separation of spaces. The semiopaque screen may be composed of a combination wall, fence, landscaped earth berm, planted and existing vegetation. All landscaping in

the buffer area must have an irrigation system. Trees and shrubs will be located so that their outermost limbs touch at the time of maturity. Suggested planting patterns that will achieve this standard are included below.

- (3) *Broken screen, type C.* A type C broken screen is a screen composed of intermittent visual obstructions from the ground to a height of at least 20 feet. The broken screen is intended to create the impression of a separation of spaces without necessarily eliminating visual contact between the spaces. It may be composed of a combination wall, fence, landscaped earth berm, planted vegetation, or existing vegetation. All landscaping in the buffer area must include an irrigation system. Trees and shrubs shall be located so that their outermost limbs touch at the time of maturity. Suggested planting patterns which will achieve this standard are included below.

(Ord. No. 978, § 4.4, 6-20-88)

#### **Sec. 32-271. Site plan review.**

Under this article, a landscape plan indicating the type, size and location of landscaping along with topography and an irrigation plan showing type and size of pipes and heads shall be submitted in conjunction with the application for the building permit. All plans shall be at a scale of one inch equals ten feet or one inch equals 20 feet.

(Ord. No. 978, § 4.5, 6-20-88)

#### **Sec. 32-272. Installation.**

Under this article, the irrigation system and the landscaping shall be installed before the completion of building construction and prior to the issuance of a certificate of occupancy unless a written agreement has been made with the city. Such agreements extending the time of installation will be for a maximum period of nine months.

(Ord. No. 978, § 4.6, 6-20-88)

#### **Sec. 32-273. Maintenance.**

The owner of the landscaped property shall be responsible for maintaining it in a healthy, clean, trimmed, weed-free and litter-free condition. Dead plant material shall be replaced with new plant material immediately. All plant growth in required landscaped areas shall be controlled by pruning or trimming so that it will not interfere with the installation, maintenance or repair of any public utility, nor shall it restrict pedestrian or vehicular traffic or constitute a traffic hazard.

(Ord. No. 978, § 4.7, 6-20-88)

**Sec. 32-274. Enforcement.**

Failure to abide by the maintenance standards of this article will be considered a nuisance subject to abatement, as provided in chapter 18.  
(Ord. No. 978, § 4.8, 6-20-88)

**Sec. 32-275. Variances.**

(a) *Definition.* For the purpose of this section, a variance shall be defined as the unavailability of sufficient land available for required landscaping.

(b) *Authority.* Where it can be shown that strict compliance with the requirements of this article cannot be met, due to unavailability of sufficient land, a variance may be sought.

(c) *Procedure.* The owner shall submit in writing a request for variance at the time application is made for a building permit. The request for variance shall detail the reasons for such a request.

(d) *Administrative variances.* A 15-percent variance to the requirements of this article may be granted by the community development department director. Any building to be structurally modified but not enlarged that does not have area to landscape due to parking and other requirements may be exempt from these requirements administratively after review during the permitting process shows an inability to comply. In all cases where an administrative variance is granted, the name and address of the applicant, address or location of the variance, and date and description of the variance shall be kept as a permanent record of the community development department, and a certificate of administrative variance shall be issued and accompany any subsequent building permit application.

(e) *Board of adjustment variances.* If more than a 15-percent variance is requested, it shall be considered by the board of adjustment. All variance requests and appeals from administrative variance requests shall be considered by the board of adjustment.

(f) *Notice of decision.* A notice of the decision of the board of adjustment shall be sent by mail to all applicants no later than ten days after the decision is made.

(g) *Appeal of city council.* An appeal to the city council if so desired must be initiated in writing within 15 days of mailing of the decision of the board of adjustment.

(h) *Fees.* Fees for all variance requests and appeals to the city council shall be as prescribed by Ordinance No. 85-041 for other variances and appeals.  
(Ord. No. 978, §§ 4.9--4.14, 6-20-88; Ord. No. 1224, § 1, 3-18-91; Ord. No. 1929, §§ I, II, 8-5-02)

**Sec. 32-276. Building permit required.**

A variance from the requirements of this article shall be automatically revoked if a building permit for the project containing the approved variance has not been obtained within one year or construction has not been completed within one year after the building permit has been issued. The board of adjustment or city council may grant a one-year extension as deemed appropriate upon application made prior to expiration of the specified period.

(Ord. No. 978, § 4.15, 6-20-88)

**Sec. 32-277. Plant materials.**

(a) *Recommended plant materials.* Under this article, recommended plant materials shall be as follows:

(1) *Trees.*

Ash (*Fraxinus* species).

Chinese pistache (*Pistacia chinensis*).

Sycamore (*Platanus* species).

Desert willow (*Chilopsis linearis*).

Honey locust (*Gleditsia triacanthos*).

Locust (*Robinia* species).

Pecan (*Carya illinoensis*).

Oak (*Quercus* species).

Mesquite (*Proposis* species).

Mexican elder (*Sambucus mexicana*).

Mimosa (*Albizia julibrissin*).

Russian olive (*Elaegnus angustifolia*).

Vitex (*Vitex agnus-castus*).

Flowering pear (*Pyrus* species).

Willow (*Salix* species).

Arizona cypress (*Cupressus glabra*).  
Pine (*Pinus* species).  
Juniper (*Juniperus* species).  
Flowering crabapple (*Malus* Species).  
Netleaf hackberry (*Celtis reticulata*).  
Arizona walnut (*Juglans major*).  
Goldenball lead tree (*Leucaena retusa*).  
Flowering plum, peach, etc. (*Prunus* species).  
Deodar cedar (*Cedrus deodara*).  
Yaupon holly (*Ilex vomitoria*).  
Texas umbrella, chinaberry (*Melia* species).  
Golden rain tree (*Koelreuteria* species).  
Cottonwood (*Populus* species).  
Cresote (*Larrea* species).

(2) *Shrubs.*

Acacia (*Acacia* species).  
Indigo bush (*Amorpha fruticosa*).  
Smooth bouvardia (*Bouvardia glaberrima*).  
Winter fat (*Ceratoides lanata*).  
Rubber rabbit bush (*Chysothamnus nauseosus*).  
Pea broom (*Dalea scoparia*).  
Sotol (*Dasyilirion wheeleri*).  
Mormon tea (*Ephedia nevadensis*).

New Mexico privet (*Foresteria neomexicana*).

Red brush (*Lippia graveolens*).

Pale wolfberry (*Lycium graveolens*).

Rosemary mint (*Paleomintha incana*).

Sumac (*Rhus* species).

Woods rose (*Rosa woodsii*).

Sage (*Salvia* species).

Arborvitae (*Thuja orientalis*).

Bird of paradise (*Caesalpinia gilliesii*).

Desert broom (*Baccharis sarothroides*).

Juniper (*Juniperus* species).

Lilac (*Syringa persica*).

Nandina (*Nandina* species).

Pampas grass (*Cortaderia selloana*).

Photinia (*Photinia fraseri*).

Pyracantha (*Pyracantha* species).

Saltbush (*Atriplex canescens*).

Silverberry (*Elaeagnus* species).

Spanish broom (*Spartium junceum*).

Texas sage (*Leucophyllum* species).

Yucca (*Yucca* species).

Abelia (*Abelia grandiflora*).

Agave (*Agave* species).



Apache plum (*Fallugia paradoxa*).

Barberry (*Berberis* species).

Barrel cactus (*Ferocactus* species).

Bear grass (*Nolina texana*).

Cholla, prickly pear cactus (*Opuntia* species).

Cotoneaster (*Cotoneaster* species).

Coyote bush (*Baccharis* species).

Boxwood (*Buxus microphylla*).

Flowering quince (*Chaenoimeles* species).

Forsythia (*Forsythia* species).

Holly (*Ilex* species).

Crape myrtle (*Lagerstroemia indica*).

Dusty miller (*Senecio cineraria*).

Euonymus (*Euonymus* species).

Gaillardia (*Gaillardia* species).

Gazania (*Gazania rigens*).

Hedgehog cactus (*Echinocereus*).

Honeysuckle (*Loicera japonica*).

Lantana (*Lantana* species).

Penstemon (*Penstemon* species).

Privet (*Ligustrum* species).

Red yucca (*Hesperaloe sarviflore*).

Rose (*Rosa* species).

Rosemary (*Rosemarinus officinalis*).

Santolina (*Santolina species*).

Turpentine bush (*Haplppappus laricifolis*).

Pittosporum (*Pittosporum species*).

Indian hawthorn (*Raphiolepis indica*).

Yellow bell (*Tecoma Stans*).

Arizona rosewood (*Vauquelinia californica*).

(3) *Ground covers.*

Blackfoot daisy (*Melampodium leucanthum*).

Ice plant (various).

Lantana (*Lantana species*).

Verbena (*Verbena species*).

Vinca (*Vinca species*).

Dwarf coyote bush (*Baccharis species*).

Cotoneaster (*Cotoneaster species*).

English ivy (*Hedra helix*).

Germander (*Tucrium species*).

Centennial (*Baccharis species*).

(4) *Vines.*

Banks rose (*Rosa banksiae*).

Queen's wreath (*Antigonon leptopus*).

Trumpet vine (*Campsis radicans*).

Virginia creeper (*Parthenocisus quinquefolia*).

Ivy (*Hedra helix*).

Wisteria (*Wisteria species*).

(5) *Grasses and low ground covers.*

Bermuda grass (*Cynodron dactylon*).

Rye (*Lolium species*).

(b) *Not recommended plant materials but allowed.* The following are plant materials that are not recommended but are allowed:

(1) *Trees.*

Mulberry (*Morus alba*).

Magnolia (*Magnolia species*).

Palms (*Washintonia species*).

(2) *Shrubs.*

Oleander (*Nerium oleander*).

Senna (*Senna species*).

(3) *Ground covers.*

(4) *Vines.*

(5) *Grasses and low ground covers.*

Fescue (*Festuca species*).

Clover (*Trifolium species*).

Dichondra (*Dichondra species*).

(Ord. No. 978, § 4.16, 6-20-88)

**Sec. 32-278. Compliance.**

Under this article, all landscaping shall conform to any requirements set forth in other sections of this Code that are applicable.

(Ord. No. 1095, § 4.17, 9-18-89)

**Sec. 32-279. Public sites and open spaces.**

(a) For the purposes of this article, the developer of land within the city limits shall provide for park and recreational facilities for the future of the city by the payment of fees or the deeding of land.

(b) The fees to be paid shall be as follows:

- (1) The developer shall pay a set park fee per dwelling unit within any zone classification that permits residential development.
- (2) If the subdivision contains more than 300 dwelling units, the developer may deed the land to the city. The decision to accept land in lieu of fees shall rest with the city.
- (3) Park fees shall be paid at the time of application for a building permit for each residential structure, residential unit, or mobile home park.
- (4) All fees received under this subsection shall be placed in a special public park development fund and shall be used by the city only for acquisitions, development, and improvement of parks and recreational facilities to serve the particular park management areas from which the fees were paid. The city adopts the park fee fund and amount as is specified in the fee resolution and management areas map as city policy concerning disposition of park fees collected and specifying areas where these funds can be spent.

(c) The minimum acreage acceptable is 2.5 acres.

- (1) The developer shall deed to the city a portion of such land both suitable and usable for park and recreational facilities. Suitability shall be determined by the city facilities department.
- (2) All improvements which front on park acreage such as utilities stubouts, curb and gutter, paving and flood control shall be provided by the developer.

(3) Land shall be deeded to the city prior to release of the plat for filing.  
(Ord. No. 1270, § I (4.18), 3-16-92; Ord. No. 1929, §§ I, II, 8-5-02)

**Sec. 32-280. University Avenue corridor overlay zone district.**

(a) Landscaping standards are established for the University Avenue corridor overlay zone district to promote the use of quality landscaping materials in such a manner as to create a more uniformly landscaped district.

(b) Landscaping for new development within the district shall be provided to cover 20 percent of the parking area for each parcel. Parking area shall be defined as the surface area of a parcel, excluding building area.

(c) Of the total area required to be landscaped, one-half shall be located within the front setback of the property. The front setback of the property shall be defined as the area between the front street curb and the property's principal structure. Landscaping for corner lots, double or triple fronting lots shall follow city design standards specifications. Businesses offering outdoor seating on their front setbacks may provide only one-quarter of the required landscaping on the front setback, subject to review by the city and the citizen's design review committee.

(d) In addition to the required landscaping percentage specified in subsection (b) of this section, all commercial, office, duplex and garden apartment developments shall be required to plant trees within parking lots for shade and visual relief. One tree shall be planted for every five parking spaces within parking lots as they pertain to the uses listed for each area.

(e) Materials for frontage landscaping and all area landscaping should be arranged so as to reflect the informal, garden-like urban landscape style of the NMSU campus.

(f) Landscape shall be defined as: One two-inch caliper tree, 15 five-gallon shrubs and a choice of either five one-gallon shrubs or 50 square feet of ground cover, for every 500 square feet of lot area excluding building area and parking lot area. The following is a list of recommended plant material for landscaping:

(1) *Trees:*

Arizona cypress.

Italian cypress.

Pines.

Chinese pistache.

Mexican fan palm.

Mesquite.

Sycamore.

Pecan.

Ash.

(2) *Shrubs:*

Spanish broom.

Pyracantha.

Pampas grass.

Juniper.

Silverberry.

Texas sage.

Euonymus.

(3) *Ground covers:*

Bermuda.

Vinca.

(g) Landscaping gravel and/or decorative stone shall be considered an acceptable additional ground cover, provided all other landscaping requirements as established in this section are fulfilled.

(h) Other organic landscaping materials may be used for landscaping within the district, provided that such materials blend visually with district landscaping material and planting style standards.  
(Ord. No. 1284, exh. C(4.17), 10-19-92)

**Secs. 32-281--32-300. Reserved.**

## ARTICLE V.

### STANDARDS FOR EROSION CONTROL

#### **Sec. 32-301. Soil and water erosion control.**

(a) Under this chapter, temporary ponding and terracing is recommended for construction sites during grading operations and measures should be continued until final paving, wall construction and landscaping is in place.

(b) Ponding below natural grade is encouraged (depressed storage). Construction of dikes to control runoff is not acceptable due to possible dike failure resulting in washouts and greater drainage problems than the original runoff presented. (Ord. No. 1789, § I, 4-3-00)

#### **Sec. 32-302. Wind erosion control.**

(a) *Purpose and intent of this article.* The purpose of this section of article V is to protect and maintain the natural environment and to reduce the health effects caused by the creation of fugitive dust, more specifically PM10, consistent with the policies of the city's comprehensive plan and the natural events action plan for Dona Ana County. This article shall accomplish the requirements of these planning documents by preventing or limiting the activities that create fugitive dust, more specifically the operations and activities associated with new or existing construction and development.

The intent of this section of article V is to prevent the contribution of man-made dust production on a regular basis. This chapter is also intended to realize that when natural events do occur, such as fugitive dust creation through high winds, the contribution of man-made dust is limited in its negative health and safety impacts. Also, the actions required within this article are not intended to cease all man-made dust generation activities when such natural events occur and the actions taken to reduce dust generation may be overcome by the natural occurrence.

(b) *Applicability.* The provisions of this ordinance shall apply to any activity, equipment, operation and/or practice, man-made or man-caused, capable of generating fugitive dust.

(1) Exemptions: Any person seeking an exemption from any of the provisions of this article shall submit a petition to the city building official for approval. The following activities are automatically exempted from the provisions of this article:

- a. Regular agricultural operations, including cultivating, tilling, harvesting, growing, the raising of farm animals or fowl, excluding unpaved roads associated with such operations.

- b. Governmental activities during emergencies, life threatening situations or in conjunction with any officially declared disaster or state of emergency.
  - c. Operations conducted by essential service utilities to provide electricity, natural gas, oil and gas transmission, cable television, telephone, water and sewage during service outages and emergency disruptions.
  - d. Temporary use of unpaved roads and parking lots which generate less than 20 vehicle trips per day for less than three successive calendar days.
- (2) *Control plan submittal and requirements.* In addition to standards established in subsequent sections of this article, if the construction and demolition operation or activity are subject to this article V, a control plan shall be required. The control plan or description requirements may be separate documents or incorporated as part of required building and/or construction plans. The following shall constitute the minimum information required within the control plan or description for reasonably available control measures (RACMs) as part of building and/or subdivision construction.
- a. Name(s), address(es) and phone number(s) of person(s) responsible for the preparation, submittal and implementation of the control plan and responsible for the dust generating operations.
  - b. A plot plan or plat of survey of the site which describes:
    - 1. The total area of land surface to be disturbed and the total area of the entire project site, in acres or square feet, depending on scale;
    - 2. The operation(s) and activities to be carried out on the site;
    - 3. All actual and potential sources of fugitive dust emissions on the site;
    - 4. Delivery, transport and storage areas for the site, including types of materials stored and size of piles.
  - c. A description of RACMs or combination thereof to be applied during all periods of dust generating operations to each of the fugitive dust sources described on the plot plan or plat. For each source identified at least one control measure must be



implemented. The same control measure(s) may be used for more than one dust generating activity. Specific details must include:

1. If dust suppressants are to be applied, then the type of suppressant, method, frequency, and intensity of application, the number and capacity of application equipment to be used, and any pertinent information on environmental impacts and/or certifications related to appropriate and safe use for ground applications;
  2. The specific surface treatment(s) and/or other RACMs utilized to control material track-out and sedimentation where unpaved and/or access points join paved surfaces; and
  3. For each fugitive dust source at least one auxiliary RACM designated as a contingency measure shall be described in the original control plan. Should the original RACM in the control plan prove ineffective, immediate and effective implementation of the contingency measure shall obviate the requirement of submitting a revised control plan.
- (3) *Control plan review and approval.* Review and approval of the RACMs shall be the responsibility of the building official or designee. Approval may be conditioned to requiring additional measures, actions, or other activities, in addition to those actions proposed within the control plan documentation.
- (4) *Implementation.* Approval and issuance of the building and/or subdivision construction permit(s) and the approval of all outlined RACMs contained within the control plan or description shall mandate the implementation of said RACMs by the developer, contractor, builder, owner, and/or agents as part of construction activities.
- (5) *Other violation prohibited.* Implementation of RACMs shall not allow the creation of other violations of these design standards or other provisions of the Municipal Code.
- (c) *General and non-construction activity standards.*
- (1) *Ground cover removal prohibited.* No person shall disturb the topsoil or remove ground cover on any real property within the city limits and thereafter allow the property to remain unoccupied, unused, vacant or undeveloped unless reasonable actions are taken to prevent generation of dust.

- (2) *Vacant land--Weed eradication and dust suppression.*
- a. For all vacant or undeveloped lots, weed eradication is limited to removal of specific weeds only through mowing or hoeing and not the removal of natural vegetation. Clearing of the entire lot is prohibited.
  - b. Once weeds are removed or mowed, dust suppression can be achieved through watering, chemical suppressant application, or the expansion of natural, non-weed vegetation areas on the site. Expansion of natural vegetation areas is encouraged.
  - c. Natural vegetation shall consist of those plant varieties that are indigenous to New Mexico or that are determined to be native or natural plant varieties by the city's community development department.
- (3) *Storage of materials and material transport.* Actions shall be taken to ensure that such areas or uses with the potential of becoming or generating fugitive dust and particulate matter, shall be covered, moistened, compacted, or otherwise treated to prevent fugitive dust creation.
- (4) *Parking time delay agreements.* For businesses that require an approved parking time delay agreement and corresponding business license with the city, the agreement shall include implementation of RACMs during the two year delay period prior to pavement installation.
- (5) *Unpaved parking lots and roadways.* Actions shall be taken to ensure that such areas or uses with the potential of becoming or generating fugitive dust and particulate matter, shall be covered, moistened, compacted, or otherwise treated to prevent fugitive dust creation. Existing, non-conforming, unpaved parking lots and roadways shall be brought into conformance in accordance with the provisions established for the expansion of non-conforming uses and structures within the zoning code, as amended, and the control plan requirements of this article.
- (6) *Existing operations.* For existing, on-going, and/or permanently-sited institutional, governmental, commercial and/or industrial facilities or operations which may continuously generate fugitive dust, individual control plans with corresponding RACMs shall be submitted to the community development department for approval. Approval shall be made by the building official/community development director or designee and shall be communicated in writing to the property/business owner. Letters of approval and approved control plans shall be kept at the property subject to this provision.

(d) *Design and construction standards.* These standards shall apply for all design and construction activities on real property within the city limits including, but not limited to, subdivisions, large lot residential, office, commercial, and industrial building construction.

(1) *Subdivision requirements.*

- a. For all subdivisions, RACMs shall be outlined and approved as part of the overall review of the subdivision construction drawings through the community development department.
- b. Developers of the subdivision shall be allowed to grade for the subdivision only after complete subdivision construction drawing approval and permit issuance. No separate grading permits shall be allowed.
- c. Letters of credits for all construction activities of the subdivision shall reflect the necessary cost of implementing RACMs for dust suppression.

(2) *Large lot residential, office, commercial, and industrial construction requirements.* For all large lot residential properties, in which the total area is greater than or equal to one-half acre, and for all office, commercial, industrial, institutional, or governmental construction activities, RACMs shall be outlined and approved as part of the building permit by the community development department.

- a. Grading activities shall only be allowed to commence after building plan approval and permit issuance. No separate grading or site only development permits shall be granted.
- b. Letters of credits for dust control plan implementation for the building may be necessary to ensure implementation of RACMs for dust suppression.

(3) *Cessation of operations.* Once construction has commenced, the disturbed area cannot sit for more than ten successive calendar days. RACMs must be outlined and implemented for all disturbed areas during periods of ceased operations more than two successive calendar days and less than ten successive calendar days.

(4) *City construction projects.* Construction activities by the city shall require RACMs outlined within the construction drawings. This applies to those projects not part of a subdivision, i.e., road reconstruction or utility replacements, or buildings not issued building permits by the city, i.e., new city buildings or utility substations. Compliance to such RACMs shall

be the responsibility of the contractor and subject to verification by the public works department, utilities department or community development department's building/project inspectors or the city architect's staff.

(e) *Reasonably available control measures (RACMs)*. Reasonably available control measures to be implemented in accordance with this article for all construction activities within the city limits shall include, but not be limited to:

- (1) Designing subdivisions or building sites to utilize existing, pre-development grades;
- (2) Watering disturbed areas on a regular and minimum basis throughout daily construction activities;
- (3) Applying palliatives or chemical soil suppressant/stabilizer for idle construction periods;
- (4) Constructing snow and/or wind fences;
- (5) Re-seeding or re-vegetation of graded or disturbed areas;
- (6) Grading for street and utility placement only as part of subdivision construction;
- (7) Building all interior and perimeter cinder block, rockwalls, and retaining walls as part of the overall construction of all subdivisions and not part of the individual building permit for each lot. Walls shall serve as wind break and help to reduce the entrainment of dust;
- (8) Grading the building pad site only plus five feet in all directions of the pad site;
- (9) Retaining natural vegetation during the construction phase of buildings excluding the building pad site;
- (10) Utilizing existing or natural vegetation as part of the required landscaping for the site as elsewhere required within these design standards, to limit grading activities, to promote water conservation, and to reduce dust generation;
- (11) Installing non-natural landscaping or vegetation in the latter part of construction to reduce the amount of disturbed area and the potential for dust generation;
- (12) Implementing any other proposed dust suppressing agent or activity approved by the building official or designee; or

- (13) Combining any two or more of the above items.
- (f) *Corrections, effective date, and enforcement.*
- (1) *Correction of condition.* If the community development department, code enforcement section of the police department, or other personnel document that a person is in non-compliance with any of the provisions contained within the article above, he or she will notify the person of that fact and specify a period of time in which the person must achieve compliance. Failure to comply within 24 hours or as the time determined by the city constitutes grounds for a notice of violation per the city's enforcement ordinances. Correction of condition may include the amendment of plans to reflect additional or new control measures to be taken in the event that original measures prove to be insufficient or ineffective.
- (2) *Remedial action.* The city community development department, its designated agent and any other authorized city representative, after proper notice, may enter upon any real property where dust is being generated and take such remedial and corrective action as he or she deems necessary when the owner, occupant, operator, or any tenant, lessee, or holder of any possessory interest or right in the involved land fails to do so.
- (3) *Costs.* Any costs incurred in connection with any remedial or corrective action taken by the city, pursuant to this section, shall be assessed against the owner of the property involved. Failure to pay the full amount of such incurred costs shall result in a lien against the property. The lien shall remain in full force and effect until all costs have been fully paid, which may include cost of collection and reasonable attorney fees.
- (4) *Effective date.* For all existing emission sources governed by this article, the activity must be completed within six months of the effective date or be brought into full compliance. For existing, on-going, and/or permanently-sited institutional, governmental, commercial and/or industrial facilities or operations, the dust control provisions of this article shall be submitted in writing, approved, and implemented within six months of the effective date of this article.
- (5) *Liability.* All persons owning, operating, or in control of any equipment or property who shall cause, permit, or participate in, any violation of this article shall be individually and collectively liable to any penalty or punishment imposed by and under the municipal code for the city.
- (6) *Offenses.* Any person who violates any provision of this article, including, but not limited to, any application requirement; any permit condition; any

fee or filing requirement; any duty to allow or carry out inspection, or any requirements by the city is guilty of a misdemeanor and shall pay civil penalty levied by the court of competent jurisdiction. Each day of violation constitutes a separate offense.

(Ord. No. 1789, § I, 4-3-00; Ord. No. 1929, §§ I, II, 8-5-02)